

"EASY-BUILD" BR Mk1 PULLMAN PARLOUR STOCK ASSEMBLY INSTRUCTIONS



THIS KIT CONTAINS SMALL PARTS THAT MAKE IT UNSUITABLE FOR UNSUPERVISED CHILDREN. SAFETY FIRST! IN ORDER TO CONSTRUCT THIS MODEL YOU WILL BE USING VOLATILE SOLVENTS, ALWAYS FOLLOW THE MANUFACTURERS INSTRUCTIONS AND ENSURE ADEQUATE VENTILATION. YOU WILL ALSO REQUIRE SHARP TOOLS AND THE EDGES OF THE ETCHED PARTS CAN BE VERY SHARP SO TAKE CARE WHEN HANDLING. PLEASE READ THESE INSTRUCTIONS FULLY BEFORE PROCEEDING WITH ASSEMBLY AS MORE THAN ONE ORDER OF CONSTRUCTION MAY BE USED.

KIT PACKING CHECKLIST

- | | |
|--------------------------------------|--|
| 1) Floor x1 | 2) Roof x1 |
| 3) Sides x2 | 4) Bogie kit (Commonwealth) with wheels |
| 5) Etched Pullman Window Frames | 6) Laser-cut glazing |
| 7) Castings And Details Pack | 8) End And Underframe Moldings x2 |
| 9) ABS Angle Extrusions | 10) End Vestibule Moldings (x2 Inner & x2 Outer) |
| 11) Wire (3 sizes) | 12) Etched Fret Of Components |
| 13) Styrene Strip | 14) Corridor Connections x2 |
| 15) Etched Brass Interior Components | 16) Comfy Cussions Seating And Table Lamps |

PLEASE NOTE: Due to the on-going production difficulties caused by the Covid19 situation we are still awaiting the arrival of the kits-specific etches. In order to prevent further delay to the release of the kit we have therefore included a combination of etched parts from our mainline stock, this includes the main etch and interior details. These items are either the same, or very similar to what is on the new etches, but you will have a significant amount of extra details left over, which we are sure you will find useful at some point in time. These instructions then are not exactly the same as will be required for use with the 'proper' etched parts, so we hope you will forgive any vagueness that might result in this first draft and please do not hesitate to contact us for clarification should you become stuck! Also, we have included the part numbers for the kits-specific etch and an image of it so you can see what we're talking about. So...

INTRODUCTION

The general idea for assembly is to construct a box with a removable roof, which enables interior details to be fitted exactly where they should be relative to window and door openings. However, please note, even if you have built an EasyBuild coach kit before, this Pullman type varies significantly in some areas, so in order to get the most from your kit we recommend you read these instructions in full prior to commencing construction. You might wish to make notes regarding any assembly options, or changes to the suggested order you think would suit your method of building better, however we suggest you do adhere to the order of construction as we know it works! We only recommend solvents suitable for ABS plastics such as Carrs Plastic Weld, or EMA Plastic Weld, Two-part epoxy resins and impact adhesives are suitable for fixing the larger metal parts. To assist you in producing an accurate model, essential dimensions and measurements can be found at the end of the instructions.

1) Let's get started by inspecting the components supplied, there's no point getting involved in construction only to find a damaged part. Start with the large moulded parts (ends, vestibules, floor, sides, roof and bogie stretchers) checking for severe warping and/or twisting. The floor and roof sections will have a degree of bow along their lengths due to the production process, but you should be able to flatten out the bow without any real effort. Whilst we take great care to weed out sub-standard parts prior to packing, some still slip through occasionally, so remember that any severely mis-shaped parts will be promptly replaced upon return to Easy-Build. Once you're satisfied with the contents, wash all the plastic components with a household detergent to remove oils and contaminants left from the manufacturing process.

PREPARING THE SIDES

2) Check the ends of the side mouldings for cutting burrs, removing as necessary, but ensuring the edge remains square and true. Likewise check all the window openings for burrs - gently scrape the edges as required, but don't be too enthusiastic with the knife!

3) Now thoroughly rub down whole side with 600 grit wet-n-dry with plenty of water and rinse with clean water. Make sure you use the abrasive paper evenly over the entire side rather than just the bits you're interested in.

***TIP - Folding a strip of abrasive paper around a small strip of hardboard works very well and ensures the abrasive paper is kept flat onto the surface of the side.*

VESTIBULES

4) Pullmans differ from all other BR Mk1 stock by having a separate vestibule at each end of the carriage and this is formed by four separate injection molded pieces comprising of an inner end, two doors and an outer end molding. Remove the various parts from their sprues and clean up as required. The doors are easy enough to identify (we hope), but the other two items need to be accurately identified to avoid problems later. See diagram right, which also shows the general arrangement for assembly.

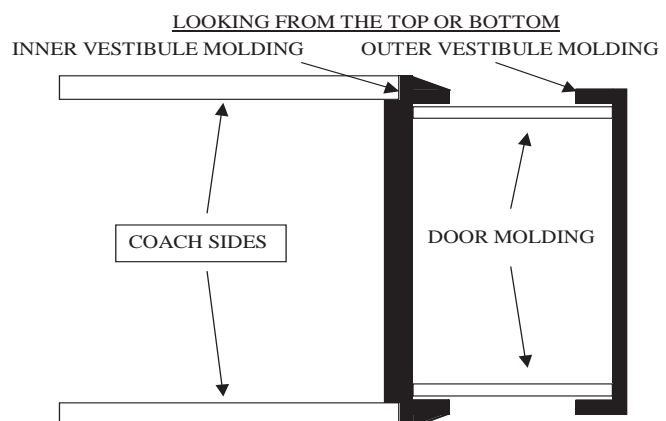

5) Having identified the parts, you now need to orientate them correctly. Again the doors should be obvious, the window position shows which way up they go and there isn't an inside and outside, just choose whichever looks best. The two Vestibule Moldings are a little more involved, but as you can see from the diagram are quite distinctive in shape, however the inner vestibule does have a top and bottom and should be orientated to match the curve of the coach sides (we might have marked the top before you receive your kit, but if not better do so yourself please)

6) Take the two Inner Vestibule Moldings and sit them onto the top face of the floor, i.e. roughly where they'll eventually be (approx. 20mm from the end of the floor molding). They need to sit flat right across the width of the floor with no gap at the outer edges, so if the edges are not sat firmly onto the floor, gently scrape away material from the centre outwards until no gap remains.

7) Assemble the vestibules as shown in the diagram above ensuring the tops of all the parts are flush. NOTE - there is no gap between the outer faces of the doors and the vestibule moldings as it appears in the diagram above, that has been done just for clarity of the parts themselves.

ENDS PREP

8) Remove the molded on details found on the outside face of the end moldings as illustrated right, noting the parts to retain and keep the molded step too. Take care doing this as the finish of the paintwork later will be affected by visible score marks of course. Finish off by sanding the entire surface as smooth as possible.

9) Drill a 0.5mm hole into the bottom edge of the cable junction boxes shown with arrows opposite, you will insert wire into these holes later.

10) Drill two 1mm dia. holes in the 'B' end - one in the bottom of the block (circled right) and a second in the bufferbeam just to the left of the central section of the end and form the pipe from 1mm dia. wire as shown.

11) Whilst drilling holes, drill the holes in the bufferbeam to mount the vac and steam heat details to either side of and in line with the coupling.

12) Turning the ends over, remove the two curved ribs that run down the outer edges of the molding and again smooth flat.

13) The ends of the pullman stock are different to all other mainline stock in that they are not curved to match the profile of the carriage sides, so a little work is needed before we can start assembling things. Take an assembled vestibule and place the outer end into inside face of the end molding ensuring it is centered across the end and scribe a line down each side of the end molding to show where the vestibule molding ends. Now carefully remove the material until the ends and the vestibules are the same width as shown right, the light grey area being the vestibule (NOT TO SCALE).

End 'A': Remove all molded details except these parts.

End 'B': Remove this part too.

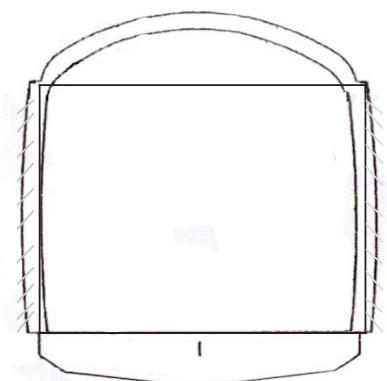
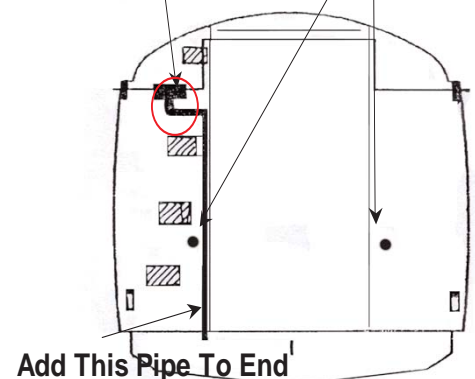

14) Fit soft copper wire into the junction box holes and add the End Cable Electrical Plugs (E7) etching having first folded it in half which will produce a slot for the wire to fit inside - folding with the etched line on the outside is essential (see photos on our CD).

15) Now add the PaxCom outer castings (C16) as shown opposite. Drill holes through the castings once in place and add the wire to represent the links to the telltales.

16) Fit the buffer heads into the stocks, you might also want to fit the end step (E9), vacuum and steam heating pipes (C17 & C18) and the coupling plate (E11) before the ends are fitted to the floor, but since some of these are quite vulnerable to damage you might prefer leaving those off for now. Don't forget them!

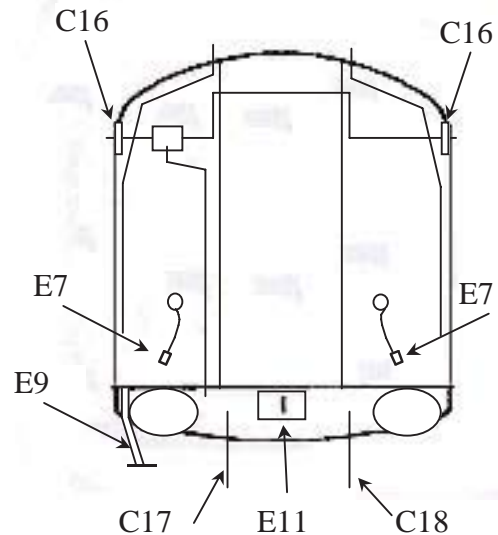

SIDES PREP

NOTE: The etched window frames do not have specific part numbers. It will be fairly obvious which frames are to be fitted into which openings. However make sure you make a note of which of the small windows openings are for toilet cubicals and fit the windowframe(s) as appropriate. Also, due to the complexity of the etched design the locating lip on the inside face of the windowframe is quite shallow (by necessity of the etching process) so some extra care is needed in positioning the windowframes, but the finished artical is well worth the effort.

17) Carefully cut the window frames from the etch and file the tags smooth taking care not to file into the frame itself. DO NOT fold out the central ventilator opening tabs of the main windows until the window frames are fitted.

18) Curving the window frame slightly makes fitting the frame easier as it will sit against the body side rather than springing away (until the adhesive sets). To do this, place the frame (inside face down) onto a curved surface such as the top of the roof moulding (ensuring the curve is in the same plane relative to the window frame as the curve of the side, i.e. horizontal) and gently press it down evenly using your fingers, directly, or a piece of thick card. As you can see from the sides, there's not much curvature required, so don't over do it.

Note: we usually suggest fitting the windowframes in place by locating the top edge first, but for some reason with these windows we've found it easier to locate the bottom edge first! However, use whichever method you find easier, but be consistent by fitting all windowframes using the top edge, or bottom edge NOT a mixture of both.

***TIP - Using a slower acting superglue may be preferable when fitting the window frames as it would allow you more time to align the window frame before the glue sets.*

19) Apply a small amount of superglue directly to the rear frame along the edge of the etched lip at the bottom only. Position the bottom of the frame into the opening and allow to set. Now, using a small piece of flat material roughly the width of the window frame, gently press the top into place and apply glue to the frame/window opening joint from the inside (this is most easily achieved with

an old craft knife blade dipped in superglue). Once the frame is secure apply more glue to the inside side joints as appropriate.

19.1) Fit the toilet window vent centrally on its backing.

20) Remove any excess glue after glue has set using a glass fibre pen, or fine abrasive paper (glass fibre pen found to be best).

FLOOR PREP

21) Check the floor molding for flatness - if it appears too distorted (some curvature is quite normal) bend it in the reverse direction to correct. Check the width of the floor moulding as they can vary as a result of the manufacturing process. The overall width should be approximately 58.5mm. If your floor is significantly wider than this reduce the width by scraping equal amounts off the outer edges of the moulding, however do not make the moulding too narrow, or it will not support the body sides later on.

22) In order to create the inset style of the vestibule ends cut the lip of the sides back to the solebar face at the ends to approximately 15mm from the ends as shown right - not to scale.

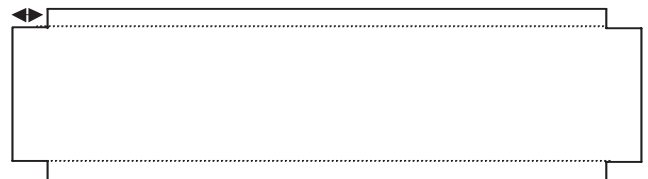

23) Place the floor moulding top side down on a flat surface to begin detailing - the bottom is that with the moulded ribs on, not the grooves.

***TIP - Fixing the floor down on to a piece of melamine, or glass with double-sided tape works very well.*

24) Remove the U-shaped and 'T' section mouldings from the sprue, cleaning off any flash as necessary. The 'U' shaped moulding are in fact slightly too tall and should be shortened by approx. 2.5mm at this stage.

25) Using the locating 'dots' on the floor surface, affix 5 of the 'U' moldings to the floor between the raised centre beams in the order of 1 short, 3 tall, 1 short. Allow joints to fully harden before continuing.

26) Pullmans have pressure ventilation ducting running between the trusses, so before fitting the angled truss moldings you need to remove sections of the central ribs to allow the ends of the ventilation ducts to cross over to the outer edges of the underfloor. Start by finding and cleaning up the castings. The long casting slides down the centre of the floor between the U-shaped moldings last fitted and is positioned centrally length-wise. Refer to the underfloor layout diagram (Page 19) to see how the four angled pieces are arranged, then mark the ribs in the relevant places and remove the ribs down the the surface of the underfloor as appropriate. NOTE: two of the angled vent pieces fit directly onto the ends of the long central vent piece so these set the total length of the ventilation system and need to be positioned to allow the end T-sections to be put in place (positioning 'dots' in the surface of the material show their location).

27) Now affix heating the ducting castings in place being careful to keep everything centralised down the length of the floor. Note that the visible faces of the ducts are slightly patteredened.

28) Cut 2 lengths of angle truss moulding 209mm and make a notch in one side of the angle 53mm from each end (see diagram on next page) - a simple cut with a junior hacksaw will create a sufficiently wide notch for our needs. Check all measurements against your underframe before cutting.

29) Gently bend the ends of the trusses (closing the notches) to pre-form to shape. Attach the formed trusses to the outside edges of the centre 'U' shaped mouldings with the notches aligned with the centres of the outer tall 'U' mouldings and the ends aligned with the edges of the shorts 'U' mouldings. Allow the solvent to harden on the centre 'U' mouldings before attaching the ends to the short 'U' mouldings as these may need bending a little more to achieve good alignment of the parts. The top of the angle should be level with the tops of the 'U' shaped mouldings.

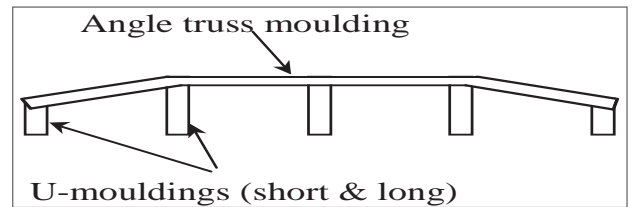

30) With the angle trussing firmly in place affix the T-section mouldings as shown in the diagram (right) between the truss angle and inner face of the solebar. There are long and short T-section mouldings supplied, the short ones are fitted against the short U-shaped mouldings (closest to the bogies), the longer ones being fitted to the centre U-shaped mouldings.

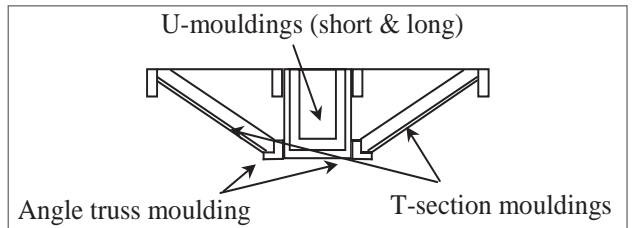

31) Locate the two metal bogie mounting turnings and prepare them by scoring their upper surface (the upper surface has a spigot that locates in the hole in the floor). Treat the mounting areas likewise. You might want (need) to reduce the height of the spigot that locates the mountings into the floor so they do not protrude into the inside of the coach and so hinder the fitting of interior details. Using a strong adhesive affix the two bogie mountings in their respective holes.

***TIP - Bogies present quite a load to their mountings mainly due to the ease by which they get knocked and twisted when the model is off the tracks, it is therefore necessary to select an adhesive capable of withstanding such shocks. Two part epoxy resins are more suitable than superglues.*

31a) To make a much stronger job of fixing the bogie pivots in place, you might consider a 'belt and braces' approach by adding a mechanical fixing to the mounting. Good results have been achieved by drilling two 1mm holes through the bogie mountings and floor (once the mounting has been fixed in place) either side of the bogie pivot bolt, tap 12BA and secure the bogie pivot in place by bolting down through the coach floor with short 12 BA countersunk bolts.

32) Clean up all the under-floor castings as required. Fold up and assemble the etched brass dynamo mounting brackets (E4a, E4b). Drill the dynamo (C8) mounting lugs 0.7mm and hang the dynamo on the etched mounting arms with brass rod. The assembly should look something like this.

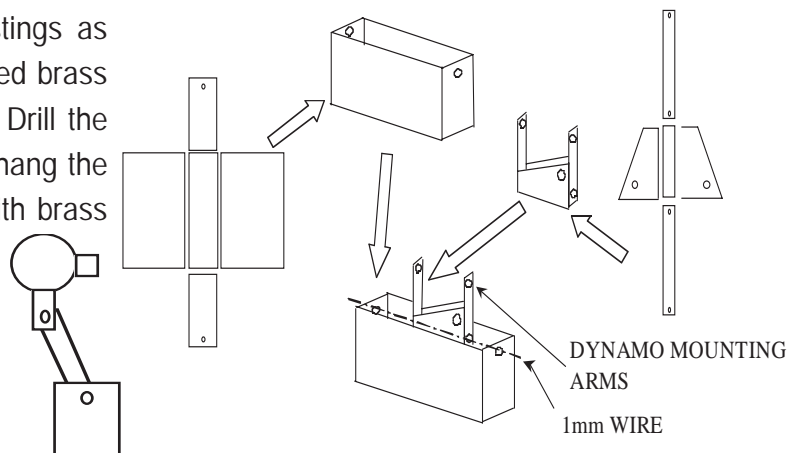

(Also see photos on our CD).

The next step uses the etched V hangers differently on the Pullmans to the way they were intended - initial kits only.

33) Remove the brake V hangers (E6) from the etch and bend the bottom edge along the half

etched line to form a right angle but with the etched fold line on the outside of the fold. This is necessary because the brake cylinder is on the opposite side of the hanger due to the use of commonwealth bogies. Also check the etched holes in the brake levers (E16, E17) and the central holes in the brake pull-rod adjusters (E18) also (0.7mm) for size and open out accordingly. - do this before removing the parts from the etch as they're much easier to handle.

34) Drill a 1mm dia. hole in the centre of the brake cylinders (C2) (there's a dimple in the middle to help) and glue in a short piece of brass rod (about 20mm protruding out of the cylinder is sufficient). To ensure the brake cylinder sits level once in position file back the mounting lug on the inside only - the central ribs of the floor are taller than the outer (solebar) ribs. Check against the floor until the cylinder mountings sit squarely and the cylinder is angled slightly towards the V-hanger. Fit the brake cylinders in place using the underfloor diagram as a plan.

***TIP - Two part epoxy resins are more suitable than superglues since they are less brittle. Good results have been obtained using impact adhesives such as Evostick (the new Evostick Serious Glue has recently been recommended although we have not tried it ourselves). Whatever type of adhesive you choose remember to roughen-up the surfaces first to improve adhesive grip.*

35) Cut two brake lever pivot bars 39mm long from 1.6mm brass rod and thread the levers and spacers (E15, E16, E17) as shown right. The first brake cylinder lever (longer lever) (E17) should be about 10mm from the end of the rod and the brake pull rod lever (the shorter lever) (E16) about 12mm from the other end, which should be the floor centreline (adjust as required). (see photos on our CD). The two sets of levers should be form a right angle relative to each other and the small lever should be directed towards the floor rather than towards the rails.

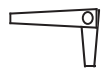
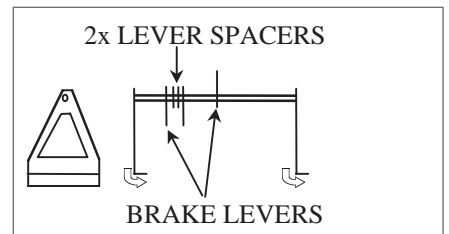

36) Attach a pull-rod and adjuster (E18) that would actually pull the bogie brake gear (see right). The pull-rod length should be trimmed to length just forward of the inner axle of the adjacent bogie. You might want to leave this off until the main construction is finished, but again don't forget it.

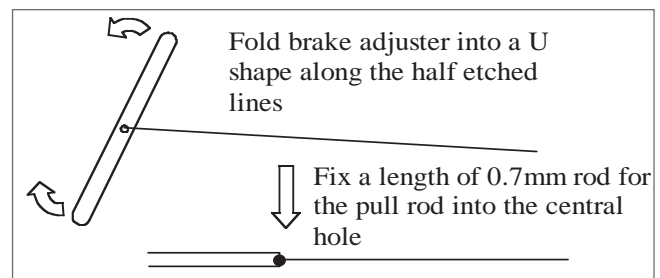

37) The Regulator Carrier Frame as supplied on the etch of these initial kits is totally different to what is required - sorry. However, it can be cut up to produce a means to support the regulator box (C7), alternatively a simple set of braces can be fashioned from scrap etch for the same purpose. The bottom of the regulator needs to be 18mm from the underside of the floor and positioned according to the underfloor diagram. Also mount the small fuse box to the side of the regulator at this time.

38) Fit the remaining castings in place according the underfloor plan. The brake DA valves (C6) mount on the sloping parts of the truss bars. Afix the brass mounting (E13) onto the rear of the casting and then onto the truss bars. The etched mounting is angled to ensure the DA valve is vertical once fitted. The positions the DA valves are shown on the underfloor layout diagram (page 19). If required, a short length of soft copper wire can be fixed to the top of the valve and into the bottom face of the brake cylinders (see photos on our CD).

BODY ASSEMBLY

There are different orders in which the parts can be assembled, all of which work, but each can produce some alignment difficulties due to the fact that the entire side is not a single piece any more. What follows is a description of what we did with notes on possible later problems. We recommend just lightly fixing the parts initially so that any later adjustments can more easily be made.

- 39) Take a prepared end and attach to the end of the floor ensuring it is stood vertically and centered across the floor. Pay particular attention to the ledge on the inside (where the bufferbeam ends) that this is level with the top of the floor molding and *slightly* too high is better than too low.
- 40) Fit an assembled vestibule to the end. This should sit onto the 'ledge' and firmly up against the end molding and solidly across the floor...
- 41) Attach each coach side to the vestibule inner molding and tack down all along the edge of the floor.
- 42) Now take a straight edge and check that the top of the sides, vestibules and ends are all at the same level.
- 43) Attach the next vestibule in place at the other end and then the end molding as before and again checking the heights.

NOTE: at this stage do not finalise the assembly by making all the joints as good as they need to be. Set to one side and proceed with the roof prep.

ROOF PREP

As mentioned previously, the MK1 Pullmans differed from all other standard stock by having a closed vestibule at each end and as a result, also have tapered ends to the roof and this needs to be represented. You will also notice your roof has a curve due to the moulding process this is useful when fitted as it ensures the roof is a tight fit in the centre of your coach.

- 44) Clean off any burrs of plastic then put a strip of masking tape down the centre of your roof onto which you can mark the positions of roof vents etc. from the sketch provided (Page 18).
- 45) Drill the marked vent positions approx. 2.0mm dia. to accept the roof vents and a smaller hole (approx. 1.2mm) for the water fillers then remove tape.

NOTE, the roof vent positions are scaled from various photographs and so absolute accuracy cannot be guaranteed. If you have more accurate information to hand please tell us and we will update our instructions.

- 46) Turning to the tapered ends, you will see we've machined the basic shape of the taper as a start. Use a [fine] flat file to blend the rough shape into the curve of the roof profile and tidy up the bottom edge and gutter lip - do not take material off the bottom just burrs.
- 47) Now the tricky bit. Remove the inside edge of the groove that locates the roof onto the body. This need to be removed for the whole length of the tapered section (about 25mm) to allow the roof to sit flat onto the molded vestibule parts - later you might also choose to reduce the height of the inner molded vestibule parts where they meet the sides to help the roof sit down. Work carefully

and steadily so as not to remove too much material and test fit regularly until you are satisfied with the fit. Diagrams are included here from our mainline stock instructions to illustrate the idea. Although the ends shown aren't tapered, the principle is the same and the second diagram illustrates the situation at the inner vestibule quite well as well as the fit of the roof to the end.

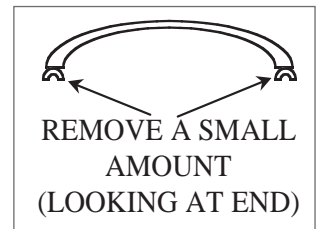

48) Cut small lengths of styrene (1mm x 0.5mm x 25mm) and attach to the bottom edge of the taper to represent the gutter ensuring they are in line with the molded gutter on the rest of the roof. The alignment is quite easy to do, but if you lay the roof onto a flat surface you can push the strip firmly down level with the bottom edge to make sure it is aligned properly. We have also produced etched parts for this ((E8) on the new sheet) that you might prefer to use, however the principle is the same.

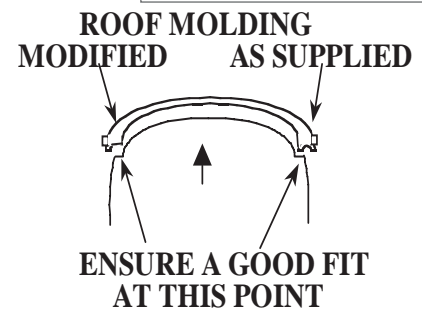

49) Rub down the whole of the roof down with wet-n-dry abrasive paper (wet 400 - 600 grit is ideal) to smooth out any surface imperfections from the manufacturing process and not forgetting the inside surface.

50) Cut the roof vents from the spues leaving no more than a 2mm spigot with which to attach the vent to the roof. Leaving the spigot longer than 2mm may interfere with the roof fixing clamps later. Affix the vents with superglue, but before fitting the water filler castings you might consider leaving them removable, i.e. create the water pipes and simply wedge them into the holes once the roof is in position. This option allows the roof to be removed without the pipes becoming vulnerable as part of a detached roof.

51) Check the fit of the long roof bolts through the hole in Captive Nut Roof Fixings (C15) then insert a nut into each and slide into the roof channel at each end of the roof to a point just behind where the taper ends. The position will need adjusting to align with the bolt holes in the floor later.

RETURNING TO BODY ASSEMBLY

52) Now using the roof as the final checking tool, fit the roof onto the body and look for alignment issues. Areas of note are the curve of the ends against the underside of the roof; the points at which the roof passes over the inner vestibule molding and the bottom of the tapered section as it meets the end (on both ends of course). Should anything be out of place, soften the joints with solvent and adjust as required. Once you are satisfied, apply solvent on all joints to create the solid welds required for a permanent job.

As noted before there are other methods of assembly, but the alignment is still a difficulty.

However, we would welcome your comments on this matter and if an easier way to assemble the body can be found we will certainly amend the instructions accordingly. Suggestions please!

53) Before moving on have a look at the whole body at the places where all the various parts come together. Some filling will be required to make the joints really smooth and this should be done now. Pay particular attention to the bottom of each end of the main sides where you will see the inner vestibule molding extends past the end of the side. Apply a blob of filler to each lower corner and shape to match the profile of the vestibule molding and the side of the coach.

54) To finish off the vestibule add a strip of 2mm x 0.5mm styrene across the top of the door 9

between the two vestibule moldings, you might also want to close up any gap between the door and floor.

55) Drill 0.6mm holes in the doors and vestibule edges for door handles and handrails. The doors are handed so the door handles are on the opposite side on the lefthand end doors. The handrails holes are 1mm away from the door edges and 11.25mm down from the top of the door window as shown right.

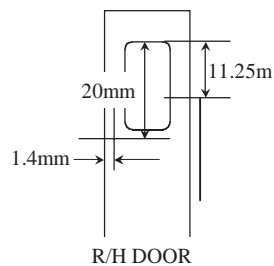

56) You can now fit any end details left off until later and the door steps (1mm x 4.8mm x 18mm styrene)

57) Next, fit the roof in place and make the water pipes that run up the ends of the coach. Unfortunately due to reducing the width of the sides you have had to remove the molded brackets that would secure the bottom ends, worse still I forgot to draw etched fixing pins as I intended! However a small loop of thin wire (0.4mm) is a neat solution for the purpose Drill holes 10mm up from the bottom of the end about 1mm in from the edge for the loops. With care a 1mm hole can be drilled into the roof water filler castings and the wires (0.7mm) soldered, or glued inside after filing to half thickness. Shape the wires to either side of the corridor connection and out towards the edges and the loops. The bottom of the pipes should be about 2.5mm below the fixings. See diagram on Page 4.

58) Now that everything is set and clean of excess glue, etc., fold the window ventilator tabs outward. First bend the tab slightly outwards using two pairs of small pliers then with a single pair close up the tabs in a **gentle** squashing action, however don't close the tabs tightly together, but leave a small gap between them.

BUILDING THE BOGIES

The steps listed here refer to the Commonwealth type of bogies used on Pullman stock and differ from our BR1B bogies in several ways. Please visit our website for graphic steps of the construction process. The main difference however, is that the side frames are handed, but are produced from the same molded part. So the first job is to make a pair of left hand and right hand sideframes...

59) First of all, remove all the parts from the sprues and clean up as necessary. Also remove the ejection pins from the rear of the sideframes and smooth off neatly.

60) Remove the small amount of material shown circled right, just cut back level with the face of the sideframe and smooth off.

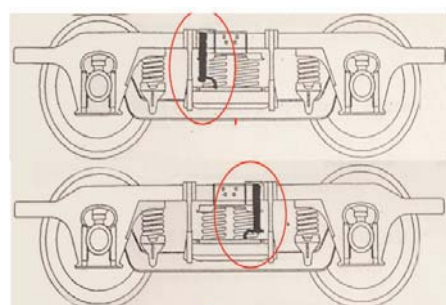
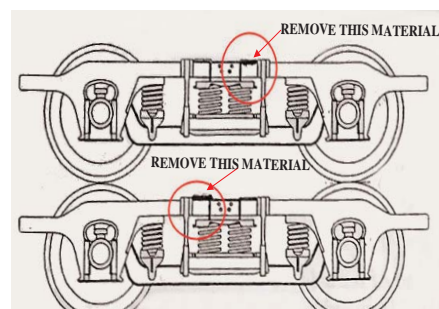

61) Affix the dampers into place as shown left noting that the bottom mounting faces towards the centre in both cases.

62) Affix the stabiliser arm brackets to the upper sideframe as shown right and far right circled.

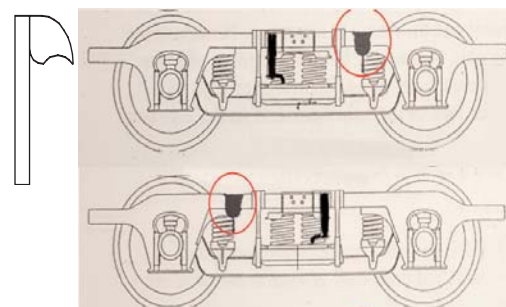

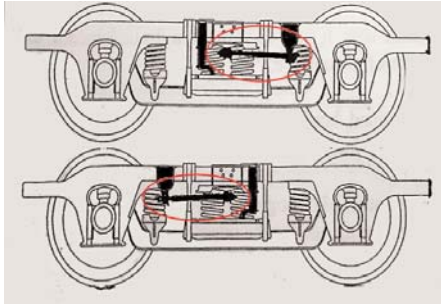

63) Affix the stabiliser arm from the small protrusion in center of the bogie to the circular cutout under the stabiliser brackets as shown left.

64) Now we need to modify the main bogie stretcher slightly by cutting off both end pieces back to the main central plate as shown right.



Now we can assemble a pair of handed sideframes together...

65) Push brass bearings into axle holes making sure they are an easy sliding fit, if necessary clean hole with a 2.5mm drill and add a tiny drop of plastic compatible oil, NOT WD 40, into each bearing.

66) Insert the bogie stretcher into the slot in the inside face of the sideframes with the reinforcing cross members facing downwards and secure in position. Ensure the sideframe and stretcher plate are square to one another.

67) Now insert the wheels and affix the other sideframe making sure everything remains square. When the side frames are securely held in place minor adjustments can still be made at this stage by applying more solvent to soften the joints and adjusting as required.

Once all the joints are set hard we can now set the axle bearings:

68.1) Centralise the wheelsets by inserting a piece of card between each wheel and the side frame to prevent lateral movement.

***TIP - Do not over-pack the wheelsets as this might cause the sides to spring inwards when you remove the card later resulting in stiff wheel movement.*

68.2) Push in the bearings from the outside until the bearings connect with the axle ends.

68.3) When satisfied that the bearings are (just) against the pinpoint ends fix the bearing in place with a drip of superglue into the hole and leave to harden.

68.4) When set remove the card and fit the axlebox covers in place. Make sure the axlebox covers are fitted centrally over the axle.

69) Remove the bogie pivot mounting from the casting sprue and remove any flash. Test the bogie pivot bolt is an easy sliding fit in the mounting hole. If tight, open the slightly with a 3.5mm drill (No. 24) to ensure a smooth swivel movement.

70) Drop the bogie pivot mounting into its locating holes in the top of the bogie stretcher plate and using only sufficient glue to attach the plates, fit keeper plates over pivot spindles. Ensure the pivots remain free to move until the liquid solvent has evaporated.

***TIP- Some people prefer to use a larger piece of sheet styrene (not supplied) rather than the molded keeper plates supplied.*

71) Fit the bogies onto the coach with the dampers to the centre of the vehicle and give a run.

INTERIOR DETAILS

72) Moving to the inside of the carriage you will need to make two saloon dividers. Again these are provided from our other interior details at this time, but are essentially the same as on the production etch. So, remove the two saloon dividers without windows and a pair of doors. Affix the door in such a way as to produce one lefthand and one righthand partition with the doors outside the saloon, i.e. on the opposite side of the wall to where the seats will be.

73) Test fit each partition inside the saloon just inboard from the toilet windows.

74) Remove all the tables from their respective etches and clean off any burrs. Now fold as shown right. The tables are too short for Pullman use so we have included an equal number of laser-cut styrene table tops. Cut these apart and clean up, then affix to the top of each previously folded table.

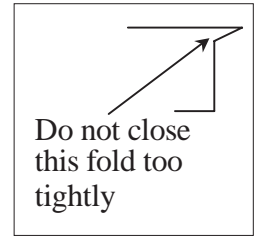

75) Locate the lost wax cast brass table lamps, cut from the sprue and clean up as necessary. NOTE: you might prefer to paint the table lamps before removing from the sprue.

76) Inspect all the resin cast seats and curtains and tidy up as necessary. You will notice the seats are handed. The 'missing' side wings have been left off in order for the seat to sit closer to the side with the curtains attached to the carriage side.

At this point it is recommended that you paint the various parts. Proceed by first giving everything a good wash with water containing a mild detergent and allow to dry thoroughly. Space does not permit a detailed description of how to paint your carriage so it is assumed that you already have that knowledge and skill, or know someone who does. If you are having difficulty in this area please contact us for advice. Some livery information can be found at the end of the instructions.

FINAL ASSEMBLY

77) Cut all window panes from the laser-cut sheet and trim off the tabs flush. Also remove the cutting cusp from around the edges by scraping and thus applying a slight bevel to the edges. This will allow the panes to sit flush against the windowframes.

78) Before fitting the window panes lightly sand the surface of two small panes on one side with fine abrasive paper (used wet) to simulate frosted glass for the toilet compartments.

79) Lay the coach on its side and insert the panes of glass into each opening and secure in place with liquid glue - NOT superglue. We recommend 'canopy glue' diluted to a milk consistency with a drip of detergent added and applied with a fine paintbrush. Repeat on the other side when dry. Don't forget the door windows in the vestibules.

80) Installing the curtains can also be done now using full strength canopy glue. Ensure the top of the curtains is about 1.5mm below the top of the carriage side so as not to interfere with the fitting of the roof.

81) Whilst the windows and curtains are drying, attach a table lamp to each table close to the outside edge, i.e. the edge that will go against the carriage side.

82) Temporarily place a seat and table at each end of the saloon with the tables centered in the window and the seat placed at a sensible distance that would allow your little people reasonable access. Now affix the saloon dividers in position against the back of the seats, but not hard up against the seat back. A simple styrene 'wall' can be made as an aid to keeping the partitions vertical and also

to depict the toilet cubicle.

83) Now install all the seats and tables permanently, aligning the tables with the centers of the windows. The 'missing side' of each seat should fit around the edge of the curtains (left and right hand pairs of both seat types).

84) Fit the door handles and handrails to the vestibules.

85) Now turn the carriage over and install the couplings.

***TIP: Crimping the end of the 12BA bolt will prevent everything coming unscrewed in use.*

86) Position the roof in place and secure with the long bolts provided. You may find the sides have bowed inward since you assembled them. If this is the case work initially with one side and locate the top of the side into the groove in the underside of the roof. Once one side is in place gentle pushing and squeezing will be sufficient to encourage the other side into place. Don't apply too much tension with the fixing bolts until the sides are located into the roof grooves as this can impede fitting.

87) Fit the water filler pipes to the ends of the coach.

88) Fit the bogies in place with the short bolts provided. Adding a smear of glue on the thread of the bolt prior to fitting will be sufficient to prevent the bolt from unscrewing during use - don't apply too much or you may not be able to get the bogies off again - not good!

89) Finally, assemble the corridor connections (see appendix page 20) and affix in place ensuring they are fitted vertical and centrally on the end - the bottom of the corridor connection should be level with the top of the corner 'step'.

And there you have it - a posh Pullman to add to your stock!

SHAWN KAY DECEMBER 2020

CONTACT INFORMATION

HMMMM - WHAT A DIFFERENCE!

Our guarantee to you is, by purchasing this kit you should be able to build a high quality model from the components supplied. To ensure this, if you damage a component return it to Easy-Build for a free replacement. If you cannot complete the model we can arrange to complete it for you - we want you to have a completed model to enjoy not a box of half completed bits in a cupboard! If you are unsatisfied with this kit, or the service you have received from Easy-Build in any way, please contact us at our Camelford address without hesitation.

"EASY-BUILD"

Trenarth, Victoria Road, Camelford, Cornwall, PL32 9XE.

Tel: 07834 063966 (before 9pm please)

e-mail: shawn_easybuild@btinternet.com web: www.easybuildcoaches.co.uk

NOTES:**DIMENSIONAL DATA**

| | | |
|---|---------------------------------------|---------|
| Buffer centre height from rail head | 3ft 5 ¹ / ₂ in | 24.2mm |
| Body height (bottom) from rail head: | 4ft 1in | 28.58mm |
| Overall body height to apex of roof (not vents, pipes, or periscopes) | 12ft 4 ¹ / ₂ in | 86.6mm |

Suitable paint is available from both Phoenix Precision and Railmatch for both the traditional umber and cream and the later refurbished grey and blue liveries. Transfers for both liveries including appropriate names and crests can be obtained from Fox Transfers, with the later livery details also being available from Railtec. NOTE: The large lining panels are created by making a box from ends connected together by straight lines. We have found the box ends to be too tall so need to be reduced in height in order to fit the available space - which is not difficult to do. We have checked our dimensions against preserved examples of these coaches and can confirm the accuracy of our dimensions. Do contact us for more information should you require.

Interior colour schemes as noted by Keith Parkin in his seminal work BR Mk1 Coaches:

| | 1 st Class | |
|-------------------|-------------------------|----------------------|
| Ceiling | French Grey | Light Tan |
| Saloon Partitions | Rio Rosewood | Rio Rosewood |
| Table Tops | Black | Sirocco (?) |
| Seats | Orange & Black Moquette | Bronze Green & Black |
| Carpets | Black & grey | Black & Green & Grey |
| | Parlour 2 nd | |
| Ceiling | Grey | |
| Saloon Partitions | Siamese Teak | |
| Table Tops | Terracotta | |
| Seats | Green | |
| Carpets | Charcoal | |

GENERIC ETCHED PARTS - TEMPORARY INCLUSION

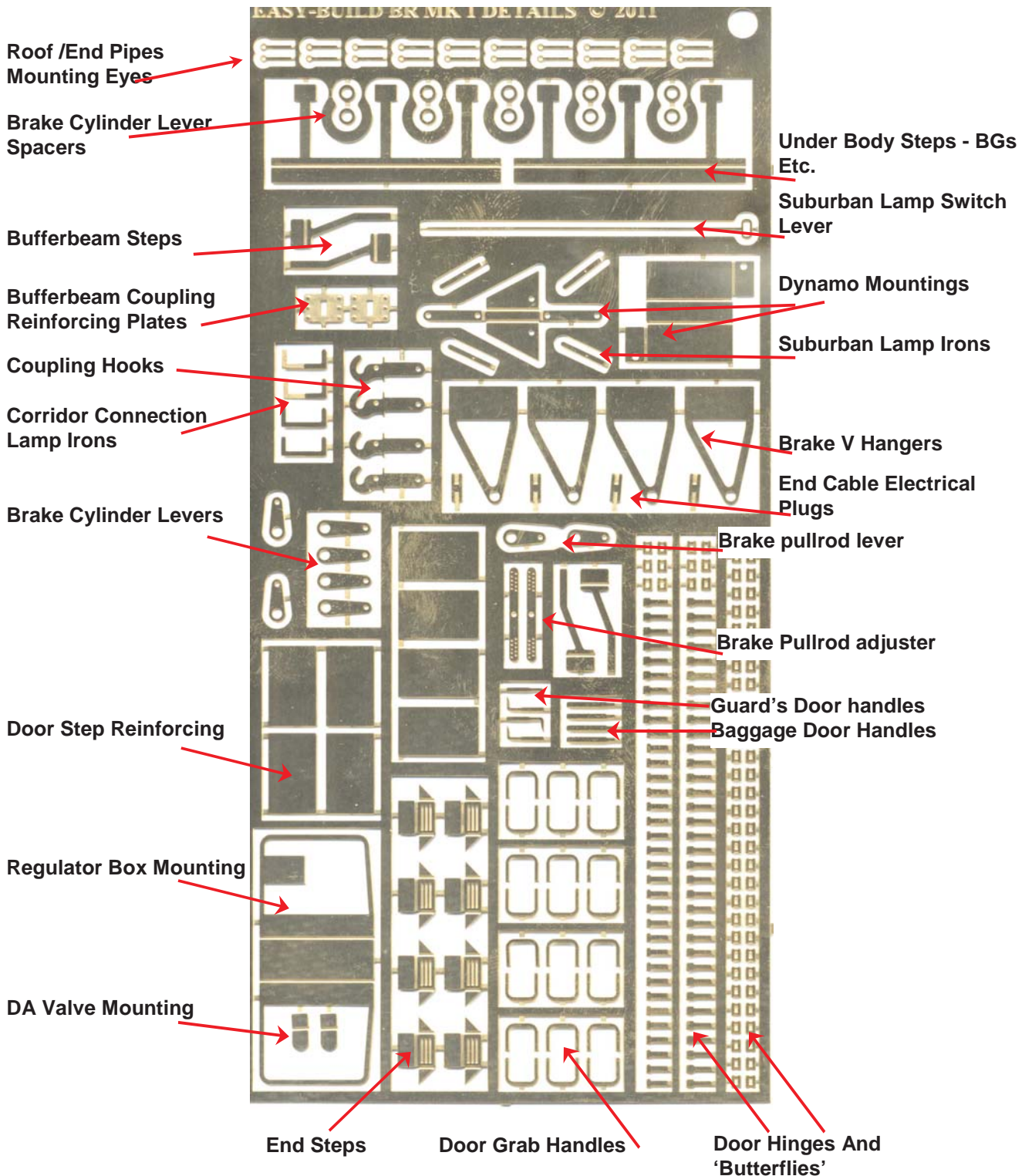

ETCHED PARTS (NOT IN INITIAL KITS)

ETCHED DETAILS IDENTIFICATION

- E1 Double Tables
- E2 Single Tables
- E3 Inner Partition 1
- E4a/ E4b Dynamo Mounting
- E5 Inner Partition 2
- E6 Brake V Hangers
- E7 Electrical 'Plugs'
- E8 Gutter Extensions
- E9 BufferBeam End Steps
- E10 Lamp Irons
- E11 Coupling Reinforcing
- E12 Regulator Mounting
- E13 DA Valve Mountings
- E14 Coupling Hooks
- E15 Brake Lever Spacers
- E16 Brake Levers Short
- E17 Brake Levers Long
- E18 Brake Adjusters

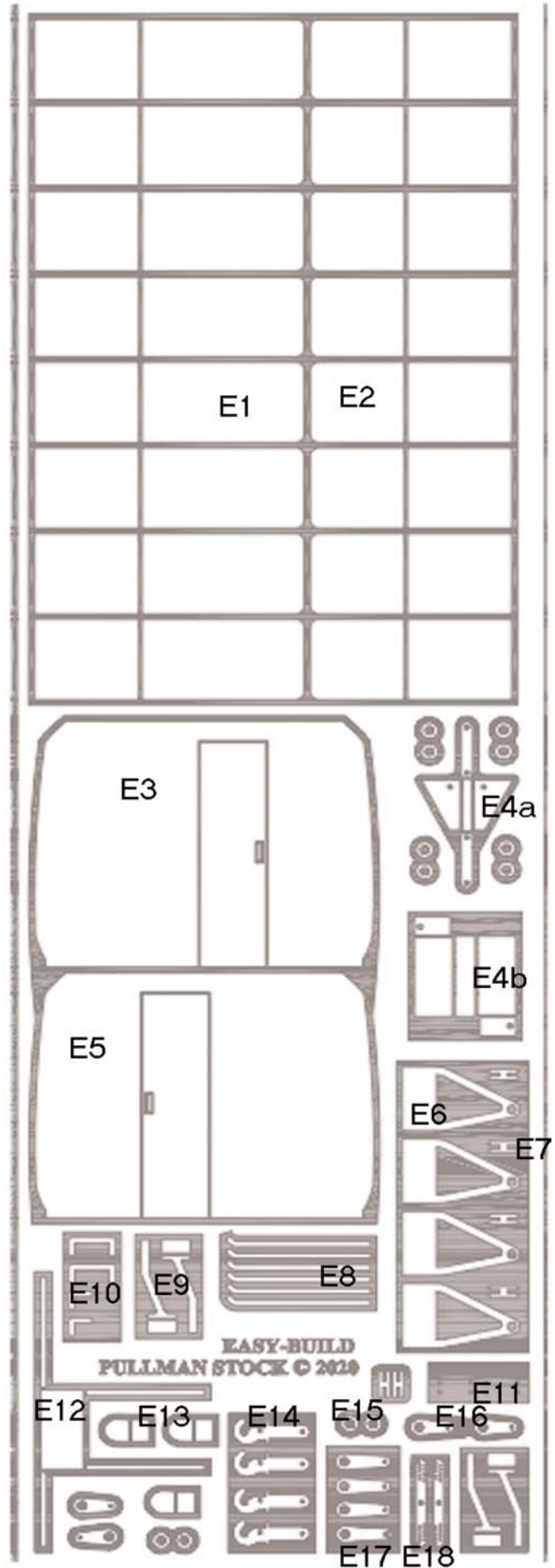

CASTINGS AND OTHER PARTS

- C1 Battery Boxes
- C2 Brake Cylinders
- C3 Buffer Heads
- C4 Roof Vents
- C5 Small Electrical Box
- C6 DA Valves
- C7 Regulator Box
- C8 Dynamo
- C9 Fuse Box
- C10 Roof Water Fillers
- C11 Door Handles
- C12 Door Handrails
- C13 Pressure Ventilation Equip.
- C14a/b/c Ventilation Ducting
- C15 Captive Nut Roof Fixing
- C16 Pax Com Brackets
- C17 Vac Pipe
- C18 Steam Heat Pipe

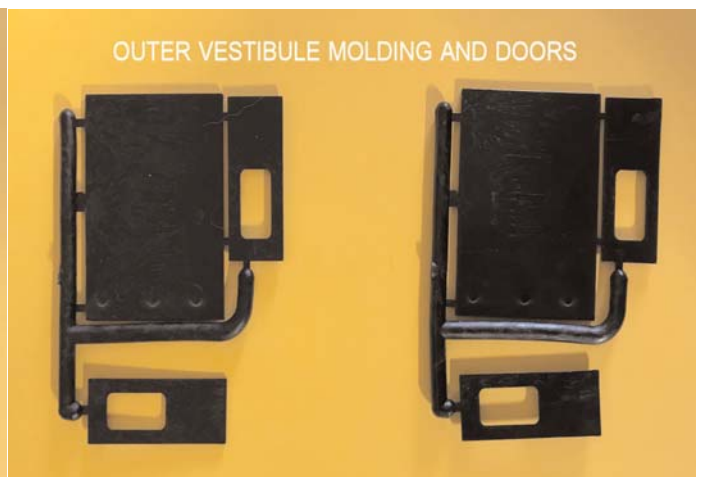
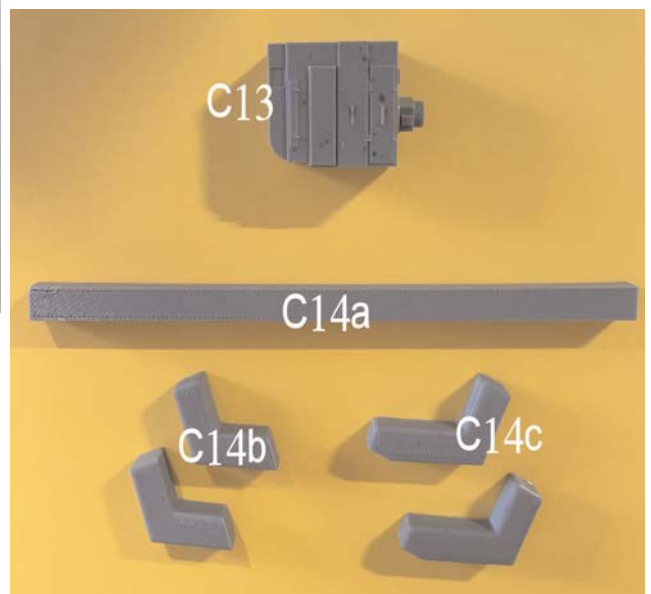
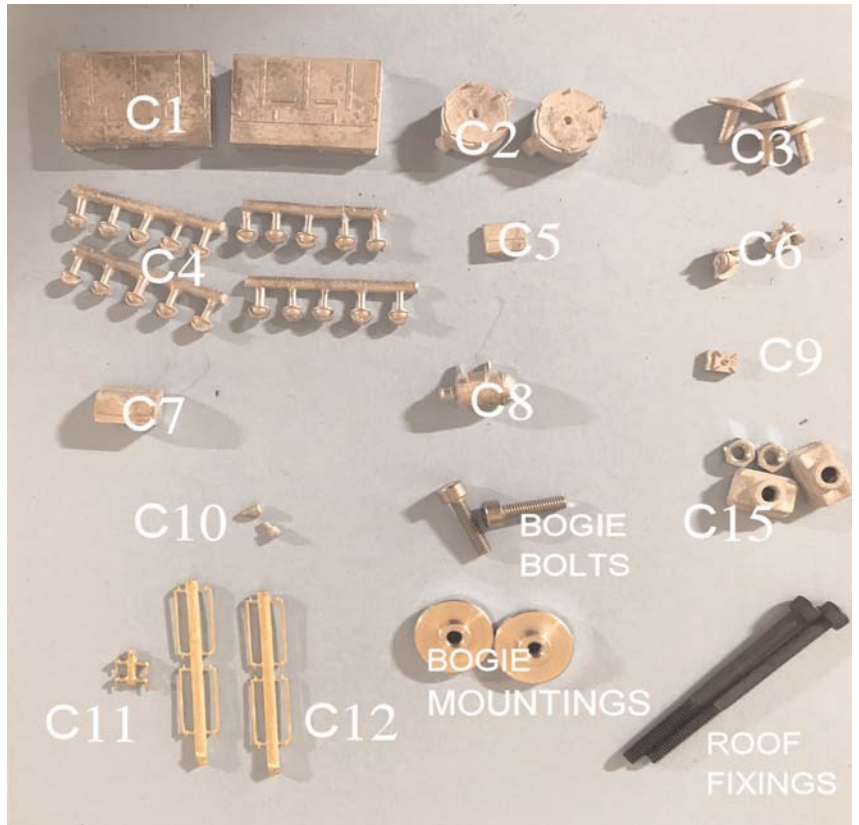

PARLOUR 2ND INTERIOR LAYOUT

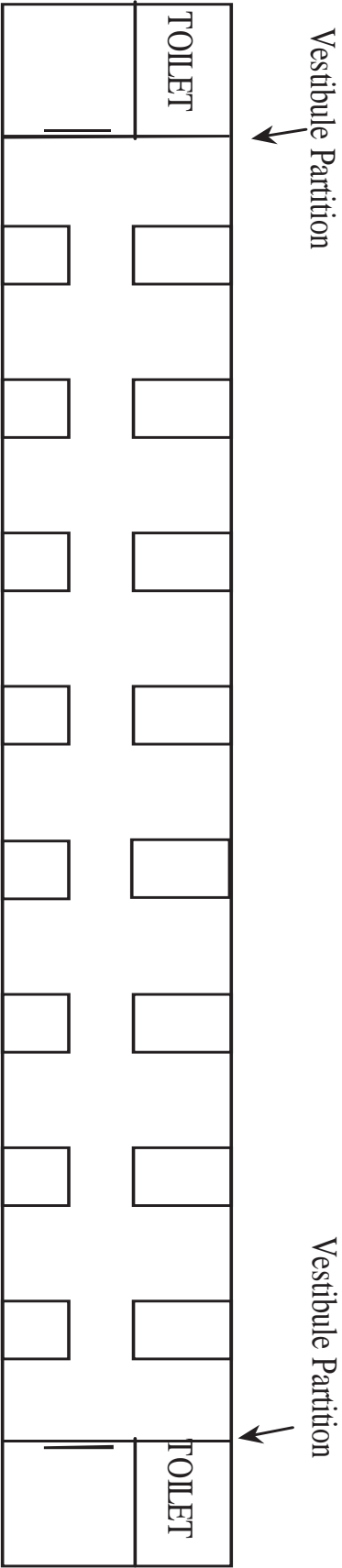

| Parlour 1 st & 2 nd Roof vents and water filler positions. | | |
|---|-----|-----|
| A | B | WF |
| 95 | 48 | 15 |
| 165 | 80 | 440 |
| 235 | 150 | |
| 305 | 220 | |
| 375 | 290 | |
| 405 | 360 | |

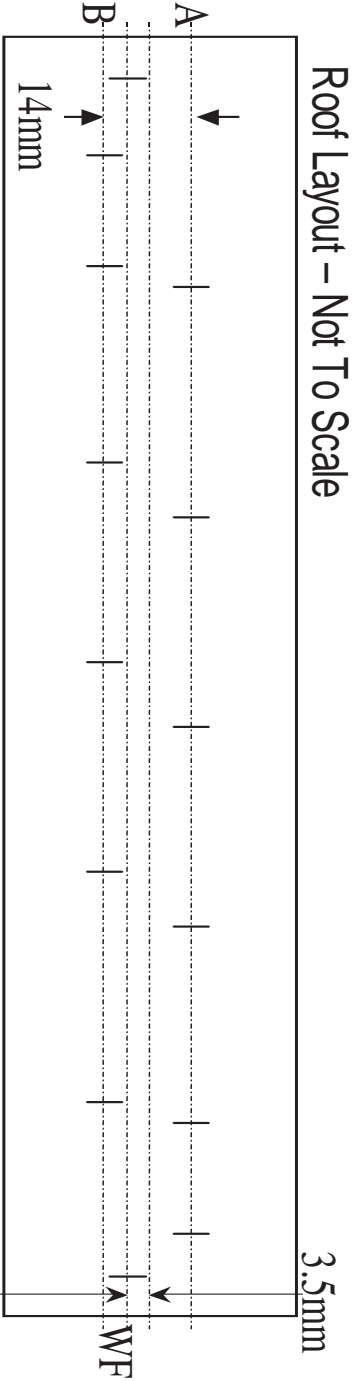

**ARRANGEMENT OF COMPONENTS OF THE
UNDERFRAME AS YOU WOULD BUILD IT
(NOT TO SCALE)**

All measurements in mm taken from one end.

KEY TO COMPONENTS

- C1: Battery Box
- C2: Brake Cylinder
- C5: Small Electrical Box
- C6: DA Valve
- C7: Regulator
- C8: Dynamo
- C9: Fuse Box
- C13: Pressure Ventilation Equip.
- C14a/b/c: Ventilation Ducting

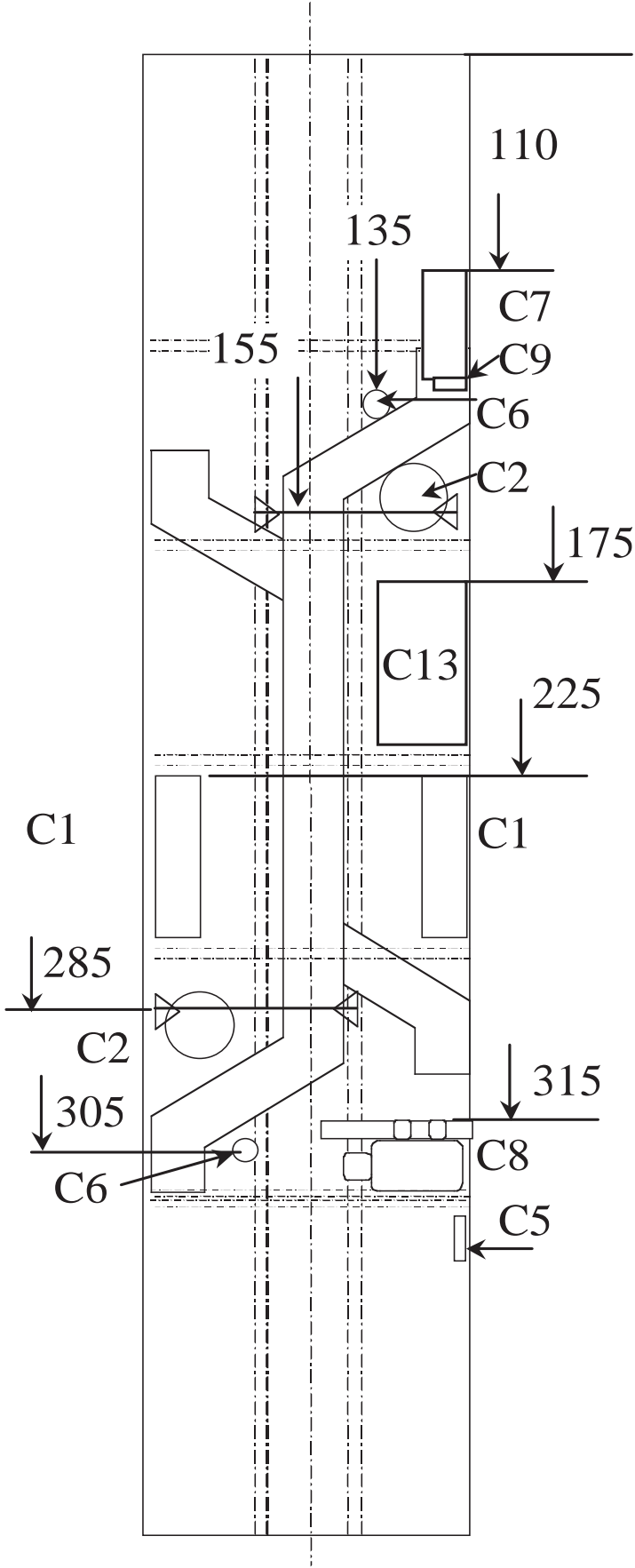

APPENDIX

Corridor Connection Assembly.

The basic components are illustrated here (right). Note that the bellows have a front and rear, with the square section being the rear. The mounting plate should be painted to match the colour of the end of the carriage, this is best done before assembly.

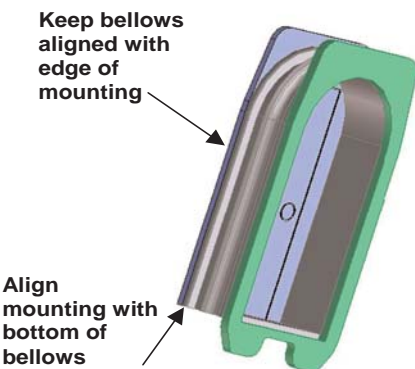
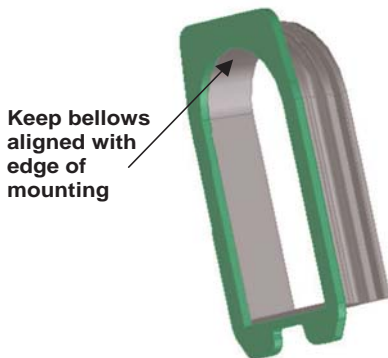
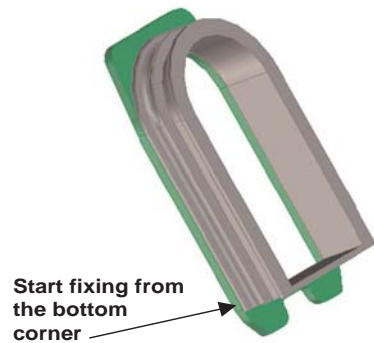
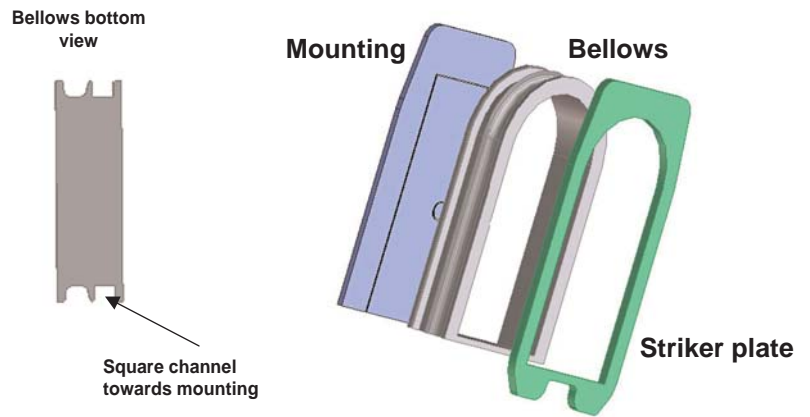

- 1) Remove the mounting and striker plates from the sprue and smooth off the feeds.
- 2) Inspect the edges of the bellows for signs of flash, which gives the edge a crinkly appearance. To remove the flash, carefully clip the thin crinkles back to the smooth edge, this is best done with scissors, or end clippers. Finish off the trimming with 400 grit abrasive paper as required. Also, give the the ends a rub over to improve adhesion.

3) The floor across the bottom of the bellows can be removed to increase flexibility when used within a train, or left in place for an end coach.

3.1) To remove the floor section, cut vertically downwards on the inside of the bellows opening with a sharp blade. DO NOT reduce the bellows height.

4) Starting at with bottom corner of the striker plate, secure the bellows with a spot of superglue. The bottom of the bellows align with the top of the opening in the striker plate.

5) Keeping the edge of the bellows aligned with the edge of the striker plate, continue gluing up the side to the point where the arch begins. STOP.

6) Repeat steps 4 and 5 on the other side.

7) The bellows around the arched opening can now be fixed ensuring they follow the outline of the curve.

8) Now repeat steps 4 to 7 to afix the mounting plate noting the bottom of the mounting is level with the bottom of the bellows. Ensure the door outline faces into the bellows before you start gluing!

9) Give the edges a gentle rubbing over with fine abrasive paper to remove any excess glue.

