

"EASY-BUILD" METCAMM CLASS 101 TRAILER CARS ASSEMBLY INSTRUCTIONS.

SAFETY FIRST! CONSTRUCTING THIS KIT REQUIRES THE USE OF VOLATILE SOLVENTS, ALWAYS FOLLOW THE MANUFACTURERS INSTRUCTIONS AND ENSURE ADEQUATE VENTILATION. YOU WILL ALSO REQUIRE SHARP TOOLS AND THE EDGES OF THE ETCHED PARTS CAN BE VERY SHARP SO TAKE CARE WHEN HANDLING. WORK STEADILY AND SAFELY AT ALL TIMES.

INTRODUCTION

In order to get the most from your kit we recommend you read these instructions in full prior to commencing construction making notes as to any assembly options. However, even if you have built one of our other DMU kits we suggest you do follow to the order of construction because this kit is significantly different to any of our other offerings. These are 'honest' instructions inasmuch as they are based on our actual experience of building the kit. If we have encountered a problem we will tell you how to get around it and where practical future examples of this kit will be modified. Diagrams and photo references will be found throughout these instructions. The images are of preserved units and so one should be aware that they might not represent precisely how the unit might have looked in service. Images from our other DMU kits found on the CDROM might also be referenced to illustrate a construction idea. To help you find the images they are identified by class and name of photo. You will also find numerous additional prototype and model images to assist you create an outstanding model.

| KIT CONTENTS | | |
|---------------------------------------|------------------------------|----------------------------------|
| 1x FLOOR MOULDING | 1x ROOF MOULDING | 2x SIDE MOULDING |
| 1x CAB MOULDING (DTCL) | 2x PLAIN END (1x DTCL) | 1x BOGIE PACK |
| 1x CASTINGS PACK (see illustrations) | 4x BUFFERS & SPRINGS | 3x ROOF FIXING CAPTIVE NUTS |
| 2x BOGIE MOUNTINGS | 2x BOGIE FIXING BOLTS | 6x SELF TAPPING SCREWS |
| 3x ROOF FIXING BOLTS | DOOR BUMP STOPS | 6x T-HANDLES |
| 1x COUPLINGS | 4x ROOF PARTITION INSERTS | ETCHED WINDOW FRAMES |
| WIRE (2 SIZES BRASS, 1x SPRING STEEL) | STYRENE SHEET (FALSE FLOORS) | 3x MOULDED FLOOR STRETCHERS |
| ETCHED BODY PARTS (2 SHEETS) | 3x BUFFERBEAM MOULDINGS | MOULDED SEATS |
| SILICON TUBING (MU CABLES) | CORRIDOR CONNECTION(S) | 1x ABS INTERNAL WALL (TBSL ONLY) |

BEFORE STARTING...

The MetCamm units as built had a distinctive look in that they did not have full length gutters above the windows. This feature creates problems that are not found on prototypes that have a gutter fitted. Later in life, the units were refurbished and were fitted full length with gutters, so before starting construction it is important for you to decide how you want your model to look as this will affect the work involved. We always stress to customers that 'Easy-Build' does not mean, nor imply 'quick to build' and that is particularly true of this kit, but with patience and care you can produce an accurate model that will serve you well for years to come. So...

GETTING STARTED

The basic steps are the same for all car types, so unless there is an operation specific to a particular body type the instructions should be applied to all units as required. Let's get started by inspecting the components supplied, there's no point getting involved in construction only to find a damaged part. Start with the large moulded parts (ends, floor, sides, roof and bogie stretchers) checking for severe warping and/or twisting. The floor and roof sections will have a degree of bow along their lengths due to the production process, but you should be able to flatten out the bow without any real effort. Whilst we take great care to weed out sub-standard parts prior to packing, some still slip through occasionally, so remember that any severely mis-shaped parts will be promptly replaced upon return to Easy-Build. Once you're satisfied with the contents, wash all the plastic components with a household detergent to remove oils and contaminants left from the manufacturing process.

1) THE ROOF OVERLAY HAS TO BE FITTED THE CORRECT WAY ROUND, I.E THERES A FRONT AND REAR TO IT. YOU WILL SEE THE ETCH (SHEET 1) HAS A LABEL 'ROOF PANEL REAR' JUST BELOW THE EASY-BUILD NAME. SO MARK ON THE ROOF OVERLAY ITSELF THE REAR WITH A MARKER PEN SO THAT YOU KNOW WHICH WAY AROUND IT GOES WHEN IT COMES TO FITTING.

PREPARING THE SIDES

2) Check the ends of each side molding true and square to ensure they will make a good joint with the cab and rear moulding. Also, remove a small amount of the moulded rib on the inside of each side at the non-cab ends, i.e. the baggage end of the DMBS and the toilet end of the DMCL - about 3mm is ample. Also check all window openings for cutting burrs and remove as necessary.

3) (TBSL) Brake units have guard's doors that, on the prototype, open inward. The guard's compartment is located in the baggage area, so the guard's door is one of the double (baggage) doors with a window in. To depict the guard's doors use a razor saw to make cuts up to the bottom of the moulded rib using the door outline scribe mark as a guide, but keeping inside the scribe lines. Now cut out the material between the cuts and file flat and horizontal to the base of the moulded rib.

DOUBLE 'BAGGAGE' DOORS

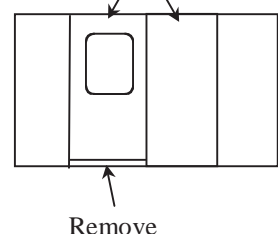

4) Take a look at the component pack and determine whether you have turned brass, or cast brass door T-handles; for the cast brass type drill out the door handle holes 0.7mm, for the turned brass type the holes are 1.0mm. Drill through all the hinge pin and bump stop holes in the sides 0.7mm dia. . The guard's compartment doors open inwards so do not have hinges.

5) (TBSL) Guard's doors also have vertical handrails either side of the door, these too need

holes drilling through 0.7mm dia.

6) Check the depth of score lines at the door positions and deepen if you prefer. Carefully remove the raised burr from the door opening scores, work steadily and re-open score marks as necessary until desired effect has been achieved.

***TIP - Use a gentle scraping action followed by fine wet-n-dry (wet is best) for these two operations. Alternatively, a small chisel can be used to shave off the burrs. Old flat needle files can be ground into chisels and are ideal for this purpose. Be careful not to dig into the surrounding surface of the sides.*

7) Give the sides a rub down with fine wet & dry to really see what the job looks like. At this stage you can go over any of the previous body prep. operations quite easily until you are fully satisfied with the results. Once the door hinges are in place it is much more difficult to do so.

You might prefer to leave off the top hinges (in the next step) until later if you are building a unit without gutters as this will ease the blending of the side/roof joint.

8) Remove an equal number of hinge pins (E25) and butterflies (E24) for the number of doors you have in your side (2 tall and 1 short hinges per door). Remember that the short hinge goes in the centre with a tall hinge top and bottom. The hinge pin piece is pushed through a butterfly shaped backing then glued into the hole in the side trapping the butterfly with the hinge, see right. Remember - guard's doors open inward so have no visible external hinges.

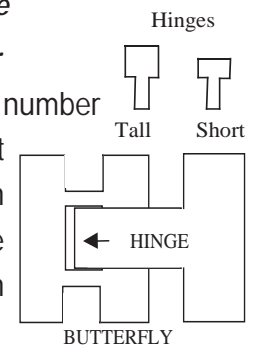

***TIP - You will find that the application nozzle on many brands of superglue will fit neatly over the hinge's spike. Once pushed through the body side push the nozzle over the protruding spike and gently squeeze a small amount of glue into the hole.*

9) Insert the lost wax cast brass door bump stops and fix in position with superglue applied from the inside. Note: door stops are not fitted to all doors. Do not fit door handles and grab irons until after painting.

10) To improve the internal finish, you might want to smooth any spikes and pins protruding from the side - it might also save a few scratches to your fingers later. This can be achieved by the careful use of a small sanding drum in a rotary motor tool, or course grit abrasive paper. Re-check the security of the components and correct any that are loose before moving on.

That completes the sides for now.

ROOF PREP

You will notice your roof has a curve due to the molding process this is useful when fitted as it ensures the roof is a tight fit in the centre of your coach.

11) We now need to make a couple of holes in the roof moulding that will be used later to position the etched roof panel. So, drill a 2mm hole on the centre line of the roof at 62mm and 350mm as measured on the centerline from the REAR, i.e the shaped end, of the roof moulding. Ideas of how to find the centre line might be a good idea. Clean off any burrs of plastic at the ends and give the inside surface a good rub over with abrasive paper. Doing this now is much easier than trying to rub it down once the unit has been assembled!

12) Drill a 1.3mm dia. hole for the water filler casting 10mm from the rear end of the roof on the centreline.

13) Remove a small amount of material (about 4mm in length) from the inner edge of the

underside of both side locating channels at the shaped end of each roof, this allows the roof to sit down over the end molding.

FLOOR PREP

14) If the floor has not already been marked, the front of the DTCL floor should be identified as that with the bogie pivot closest to the end of the floor molding (approx. 50mm). On non-driving trailer cars the front of the floor has the bogie pivot farthest away from the end (approx. 58mm).

15) Check the floor molding for flatness - if it appears too distorted (some curvature is quite normal) gently bend it in the reverse direction to correct.

16) The floor moldings will need to be reduced in width to obtain the best fit inside the body. Initially, reduce the floor width to approximately 58mm wide by carefully shaving off small amounts evenly from each side to keep the floor central to the body. This is best done using a scraping action with a sharp blade. This operation may need to be repeated when the body and underframe are assembled for the first time.

DTCL CAB ENDS PREP

17) The underside of the cab roof (where the roof meets the door opening) is slightly angled (a production process aid), carefully file this angle square in order to accurately fit the sides. Check the fit of the sides against the cab ends - make sure you've got the correct end of the side to work with, i.e. the non-baggage, and non-toilet ends. The sides should be level with the bottom edge of the cab.

***TIP- Number the ends and sides on the inner surfaces to ensure each side mates with it's appropriate end later on.*

18) Determine how many lights you require on the front of your unit, 2,3 and even 4 lights graced the fronts of these units over the years! Using the small raised circles as a guide for positions, drill out 4.3mm and fit lamp castings (C4) into the holes. Carefully sand off the raised circles you do not need.

19) If fitting the two character headcode box, remove the mounting frame (E20) from the fret and clean off the burrs. Fit the frame in the centre of the cab front and 2mm up from the bottom of the cab. If you want to illuminate the box, cut out the area of front of the cab inside the etched frame. Do this now as it's much easier to do before the unit is assembled.

20a) You will see the outline of the destination box above the cab windows, this is used in a couple of ways. If you intend to illuminate it, cut out the centre of the moulded outline then remove the rib. Cut and test fit a 'glass' panel to fit into the rebate in the back of the frame E16. The frame is fitted after painting.

20b) Alternatively, just trim the moulded ribs sufficiently to allow the etched frame to sit in place. The area inside the moulded ribs can be simply painted black, or a printed label fitted inside, covered with clear film and then the etched frame fitted after painting.

21) Remove the cab window frames (E21 & E22) from the etch and remove the burrs from the outer edge. You might prefer to leave the etched parts found inside the frames in place until the frames have been fitted as they do add strength to the frames and makes them easier to handle. Either way the tabs on the inside edge of the frames are easier to sand flat with the frame mounted on the cab front. Affix in place with superglue - method: apply glue to the top of the inside face (the side with the lip) and press into the opening keeping the lip firmly against the opening. Now apply more glue around the outer edges of the frame using a knife blade and press firmly down. Clean off excess

glue by gently scraping and/or a scratch-brush.

Prototype photographs reveal that not all units carried windscreen wipers on both left and right cab windows (the centre window never has a wiper).

TIP: use a wiper blade (E17) from inside the cab window frames as a template to drilling the holes before the wiper has been removed from its surround.

22) Drill two 0.4mm dia. holes per wiper in the centre of both, or right hand side window only (your choice) directly above the upper window beading to mount the windscreen wipers later.

23) Checking the fit of the cab glazing now is much easier than when the unit is fully assembled. Remove the laser-cut glazing from the fret and sand the edges until the panel will fit snugly against the brass frames. This will mainly entail removing the raised burr left from the cutting process, but some size adjustment might also be required. Carefully store the panels to avoid scratching the surfaces.

24) Make up the cab desk next using support (E18), desk top (C38), control details (C33) and brake hand wheels (E32). The reason for doing this now is so that you can test fit it easily. In order to make re-fitting the desk easier fix a block of scrap styrene, or even wood to the back of the desk support and securing the desk in place with a small screw through the cab floor. Obviously the desk can simply be glued in after painting.

Image: ControlDesk.JPG

25) With the control desk set inside the cab, attach the switch panel (E14) to the drivers side of the control desk. The panel just stands on top of the desk with the angled edge close to the front of the cab. Soldering works very well for this as it's quite easy to adjust the position, but superglue can also be used.

NON-CAB ENDS PREP

26) 'Front' End (non-driving units) - Remove all the moulded on details - end step mounting pads (raised rectangular details up the left hand side), connector details (the two round 'blobs') and emergency brake tell-tale details flush with the surface of the end.

'Rear' End (all units) - Leave the pipe retainers at the lower outer edges of the end and drill a 0.7mm dia. hole through the mounting for the water pipes to be fitted later.

TIP: Removing these details is best achieved by shaving small amounts off with a sharp blade, followed by a fine file and finally fine abrasive paper. See photo: End prep (Cl. 105 model).

27) Give the ends a final inspection and rub over with fine abrasive paper before moving on.

BODY ASSEMBLY

Whilst the solvents used to assemble the components evaporate very quickly the joints they produce take considerably longer to achieve maximum strength. DO NOT RUSH THESE NEXT STEPS. Leaving ample time for the joints to harden is essential and you will be rewarded for your patience by not having unsound joints later on. Both driving and non-driving units follow the same method so simply replace the cab with a plain end on non-driving trailers.

28) Fix a cab end to one side at the opposite end to the toilet/baggage compartment and the non-cab end to the other side adjacent to the toilet/baggage compartment to form an 'L' shape.

Assuming care was taken when preparing the ends and sides your sides will be level at the bottom. Ensure

the outside faces of the sides are aligned with the top and bottom of the cab door cut-out. Allow the ends to harden before attempting the next step.

***TIP - Working on a glass sheet will aid accurate bottom alignment of the sides and ends.*

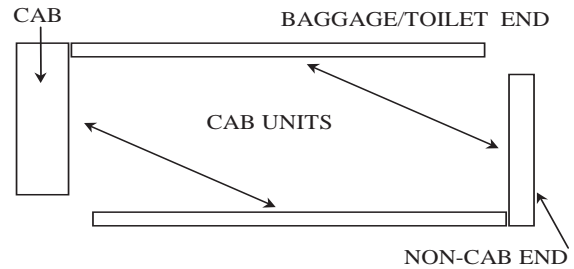

29) Assemble the two half boxes again using a flat surface to aid alignment. The box may twist a little to during this process due to the flexible nature of the materials, but do not worry unduly as the roof will bring everything back in line later.

LEAVE TO SET HARD AND BUILD THE BOGIES

The instructions here initially refer to an un-powered bogie. Note also that the bogie spues contain parts that are not intended for the DMU so please refer to the illustrations to identify the appropriate parts to use. We describe the assembly of a single bogie repeat as required!

30.1) Remove a bogie frame stretcher plate from the casting sprues and cut off the ends level with the inside edge of the moulded angle (see illustration). NOTE: On the front bogie of a cab unit (DTCL) only remove half of one end which will leave the end flush with the end of the sideframe. Clean up and square off as necessary.

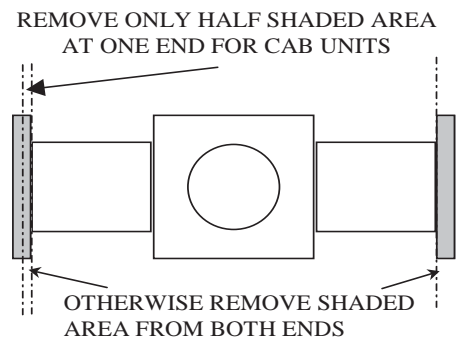

30.2) Remove the sideframes from the sprues and clean up the feeds and any flash present. The MetCamm bogie side frames come in two types: square ends & with sloping ends. You will find angled beads at the ends of the sideframes on the rear. Cut the ends to the shape as appropriate by cutting through to the back of the springs taking care not to damage the spring hanger detail. Now remove the unwanted material and file/sand smooth. Leaving the ends square is easiest and is not very evident once the bogies are in position. To be honest we only discovered the sloping ends after the new sideframes had been made and making another moulding was not cost-effective, hence the mod.

30.3) Press the brass bearings into the axle holes making sure they are an easy sliding fit, but not sloppy - if necessary clean hole with a 2.5mm drill. Do not glue in position (yet) as adjustments will be made later.

30.4) Using a pin, add a tiny drop of oil (NOT WD 40) into the bearing surface.

30.5) Place two non-driving axles in the bearings of one side frame and, ensuring correct orientation of bogie frame stretcher plate (reinforcing cross members down), assemble the side frame to the frame stretcher.

30.6) Once the first side frame is reasonably firm, assemble second side frame onto frame stretcher in the same manner. When the side frames are secure enough to hold themselves in place, make certain all is square and in line, minor adjustments can still be made at this stage by applying more solvent to soften the joints and adjusting as required. Note: wheels should be a loose fit in the bearings at this stage. Leave the bogie to set for at least 1 hour, 2 is better.

With the joints set hard you can now set the axle bearings:

30.7) There is more side-play evident in these DMU bogies than is found in our other DMU bogies. due to a slightly different design to the rear of the axle boxes. Adjustment of the bearings is achieved by pressing the bearing inwards towards the axle end. Use scrap card to centre the wheels in the

bogie, then press the bearing gently up against the axle end. Remove the spacing card and assuming the wheels revolve freely apply a small drop of superglue (or some other glue) to hold the bearing in place.

NOTE: Do not over-pack the wheelsets as this might cause the sides to spring when you remove the card later resulting in stiff wheel movement.

30.8) Remove the bogie pivot mounting from the casting spue and remove any flash. Test the bogie pivot bolt is an easy sliding fit in the mounting hole. If tight, open the slightly with a 3.5mm drill to ensure a smooth swivel movement.

30.9) Drop the bogie pivot mounting into its locating holes in the top of the bogie stretcher plate and secure in place. For this kit we include etched brass bogie pivot retainers (E4). These can be either glued in place as before (using superglue), or attached by screws (not supplied). Should you want to fit pickups to a bogie they can be soldered directly to these brass plates (hence the option to screw them in place).

30.10) If desired, fit the brake shoes on the inside of the sideframe. They should be positioned just off the wheels with the circle detail on the shoe just visible below the bottom of the side frame.

30.11) Fit the bolster detail (see photo: Bogie Sprue Labelled - Cl. 108 model) centrally to the inside of the sideframe by placing the square beam against the back of the sideframe and butt against the underside of the bogie stretcher.

While the basic bogie assembly sets, identify and remove the bogie front channel, guard irons, speedo drive mount and bogie steps from the etched sheet.

30.12) Fold up the bogie channels E28 (plain), if building a cab unit modify the channel part E27 as shown before folding. For non-cab units E27 can be folded without modification, however reduce the length of the channels that will not have guard irons attached later sufficiently to sit between the sideframes of your bogies. We designed the channels along the lines of our other kits, but then found the underframe component clearances to be much tighter and so the channels have to be 'set in' level with the end of the sideframes. The front channel with the guard irons is not affected and should be fitted as designed.

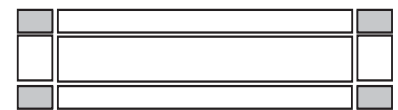

PART E27 - REMOVE SHADED AREAS FOR CAB UNITS

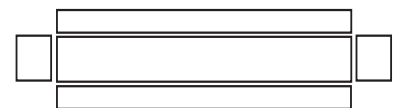

30.13) (DTCL) Fold the guard irons (E47 (L/H & R/H) along the half etch and affix at the end of the channel with the top of the guard iron level with the top and butt up against the end of the channel section. Note that only the front bogie, i.e. the cab end, has guard irons fitted.

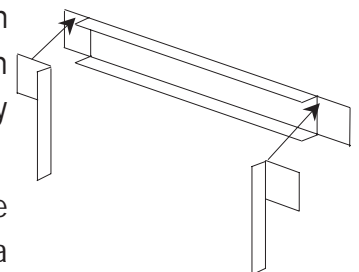

30.14) Add the dynamo mounting (E41) and dynamo (C16) centrally to one channel - the square block on the dynamo goes to the bottom. Adding a length of curved 0.6mm copper wire (not supplied) between this box and the top of the channel gives the impression of the power cable.

30.15) Glue the bogie channels to the front and rear of each bogie with the bottom of the channel level with the bottom of the sideframe (superglue is recommended for this). The channels should not extend beyond the sideframes which is why we reduced the length of the bogie stretchers (step 34.1), the is important due to how close the underframe details are to the bogies. The arrangement of the channels should be:

Front bogie (cab units): guard irons (front of bogie) and plain channel (rear of bogie).

Front bogie (non-cab units): plain channel (front and rear with dynamo).

Rear bogie (all units): plain channels both front and rear of bogie.

30.16) (DTCL) Fold up two bogie step mountings (E26) as shown right.

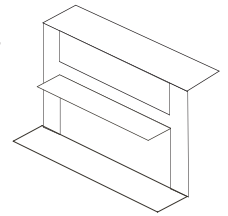

30.17) Glue the speedo drive mounting (E30) to the front left axle box. The spike faces right and down when fitted in place.

30.18) There are two different types of axle box covers supplied in the kit, use the slightly domed Timken covers. Fit covers to all remaining axle boxes. Image: *Bogie speedo drive.jpg*.

30.19) Glue the bogie step mountings in place on top of the bogie sideframe with the front mounting in line with the front spring hanger. Ensure the step is kept parallel to the side frame.

30.20) Cut enough (four, or eight) 5mm x 0.8mm styrene strip into 15mm lengths for the step treads and fix to the step supports as required.

BODY ASSEMBLY CONTINUED...

NOTE: BEFORE PROCEEDING MAKE SURE YOU HAVE GOT THE CORRECT ROOF AND BODY PAIRED TOGETHER. DMBS WITHOUT WATER FILLER DETAILS TO THE REAR, DMCL AND THE ROOF WITH THE WATER FILLER CASTING HOLE.

31) In order to ease the assembly of the body parts we suggest using captive nuts (and long bolts) set in the roof channel that will then be used to clamp the roof in place until the adhesive has hardened. Slide three square captive nuts into the channel - slightly reducing of the width of the captive nuts will make their fitment easier, however don't overdo it as you don't want them sliding about too much when trying to screw the floor in place.

32) Assuming everything has been assembled accurately the roof should fit neatly against the cab molding at the front with the rear overhanging the end by about 0.5mm. When the roof is in place the top of the sides will locate in the groove under the gutter. You may find the central moulded channel on the underside of the roof needs trimming back to enable to roof to fit between the cab and the rear end moulding. Fix the roof in place by initially applying solvent from the inside along the joint of the cab/roof moulding then along the joint between the roof and the side molding, again from the inside. Be generous with the solvent as you are going to be doing a substantial amount of work around the roof/side joints later.

33) Now clamp the floor in place using the long bolts provided and set aside to harden.

TIP: fit the floor moulding upside down into the body, i.e. with the solebars uppermost, as this makes it much easier to keep everything together whilst the adhesive is still very soft.

LEAVE BODY TO HARDEN

34) Once the roof has firmly set, slide the captive nuts out of the channel, this is easiest done by sliding them towards the cab. On the TBSL one captive nut should be left inside the guard compartment area to secure the floor in the finished unit.

35) Take time now to inspect the fit of the roof outline against the end molding. Due to the different means by which the roof and ends are produced, it will be found that the alignment of the roof line and the ends (DTCL) requires blending with an appropriate car body, or modelling filler. Likewise add filler to the underside of the roof and the top of the non-cab ends.

36) Sand the cab/roof joint until the profile is seamless. The rear of the unit, or both ends 8

on a non-cab units should now be trimmed and sanded to produce a flush finish. The roof has been cut slightly too long quite deliberately so that you can produce a vertical face up to the top of the roof

If you're making the gutterless version, take a deep breath and, if you're doing this on the kitchen table, make sure the wife, partner, girlfriend, manfriend, or house-proud pet is out (!) and proceed as follows...

37a) Remove the moulded gutter! This is best done by scraping with a sharp knife, but be aware it makes an awful mess! Obviously, keep the point of the blade away from the body side surface as it would be very easy to gouge into them. You will probably be quite timid initially, but be confident and the job will go quite quickly. There's not an easy way to describe how far to go, but what you're aiming for is to make the roof/side joint pretty-much disappear. You might think it's impossible, but keep at it... Eventually the side and roof surfaces will come together, now you will need to blend your scraping efforts into the main body of the roof to regain some of the profile you inevitably have removed. Using a selection of various grades of abrasive paper (used with water) and more scraping and possibly some filling, the joint can be made to vanish. This is not a quick job, but do not rush, it will be worth the time taken. I have included four photos on the disk that show this being done (Scraping1.jpg to Scraping4.jpg). You will notice they show the body with the brass window frames fitted, that was a mistake as it made it very difficult to sand the body to achieve the final blending of the parts. One point to remember during this process is the door scribe marks - obviously these marks need to be retained so some re-opening of the marks might well be necessary especially at the very top during this scraping/sanding process.

TIP: Spray water over the joint area and inspect the results of your work. The glossy effect of the wet surface will help to show up places where more work will be required.

37b) For those choosing to leave the gutters in place all you need to do is extend the gutter forwards over the cab doors to the front of the cab. We don't provide any material for this, but a piece of square styrene rod sanded to blend at the roof gutter joint is all that is required.

38) We can now fit the roof panel. Remove it from the fret (noting which end is the rear if you didn't do that earlier) and trim the tabs flush. Rolling the panel is not too difficult as long as you can find something round - a bar, or tube and a slightly flexible surface - a thick wad of newspaper, or rubber mat for instance. Simply place the panel face down and roll steadily back and forth with a firm even pressure. The ends will always curve more quickly than the centre so you might need to flatten the ends a little once or twice in order to get the middle to the curve you're looking for, which is slightly tighter than the curve of the roof itself.

The panels on the demo models were rolled using three pieces of 3 inch diameter plastic guttering downpipe, two of which were held in a woodworking vice and the third pressed and rolled over the top (see right). Again, taking your time is essential.

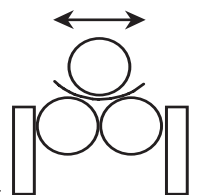

39.1) Fitting the roof panel is straight-forward as long as you drilled the alignment holes. Make sure you've got a couple of pins/screws/bolts that will pass through the alignment holes (but not a sloppy fit). You will also need to be able to clamp the panel in place to ensure it looks like it's been rivetted in place. Placing the unit onto a flat plank of wood and binding the panel down with tape should also work. The key is to apply the clamping force evenly across the whole width *and* length of the panel. Gather everything you'll need before starting.

39.2) On the demo model we tried two different adhesives: two part epoxy resin and PVA wood glue! Having used both, we recommend the PVA because it is easier to work with and easier to

clean up afterwards. So, brush a thin coat of PVA over the underside of the roof panel without going too close to the various roof vent holes, but getting good overall coverage and, making sure it's the right way round place onto the roof and align with the pins.

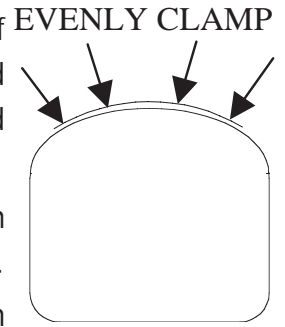

39.3) Apply your chosen method of clamping/binding and clean as much adhesive that squeezes out at the edges as possible. Now set aside to harden...

39.4) Having removed the clamping, give the whole panel and roof a good clean up. No doubt there will be a fair amount of excess glue to remove (if not, you probably didn't use enough!) and inspect the edges of the panel - it should be firmly down onto the roof all around. To seal the job apply superglue to the edge of the panel using a knife as an applicator. Method: make a pool of superglue, dip in an old blade and run it along the panel/roof joint so that any small gaps will be filled with the adhesive. Once again clean off excess adhesive with a scratch brush. Repeat as necessary.

40) Remove 15 moulded roof vents from the plastic spue (the bufferbeam sprue) and clean up any flash. Drill out all the holes in the roof panel 2mm diameter and fit the vents. Although they are plastic we recommend using superglue here as the mounting pin is quite short - the angled ends face down the length of the roof.

41) Form and fit the water pipes to the filler casting on the roof and down to the brackets moulded onto the end. Use 0.7mm brass wire for the pipes, file the ends of the two halves flat, solder together, drill a hole through the body of the filler and insert the pipe end. See photos for shape of pipe run (*WaterPipes Top.JPG & WaterPipe End.JPG*). Cut off the pipes about 3mm below the retainers.

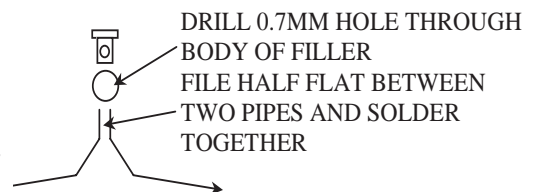

UNDERFLOOR ASSEMBLY

NOTE: The molded ribs on the floor molding determine the underside of the floor molding!

42) Re-check that the floors will fit within the sides and end molding and trim as required.

43.1) There are two sets of etched brass solebar overlays provided E2: SOLEBAR BRAKE CARS and E3: SOLEBAR NON-BRAKE CARS and select the correct solebars for the type of unit you are constructing.

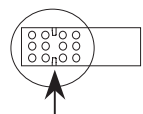

43.2) For non-cab units the solebars need shortening slightly. You will see two notches etched into the rear of the solebars between the four rows of rivet dimples at what is the front of the solebar (see right). Cut the solebars at this point, and remove any burrs.

44) Impress the rivets in the solebars with either a riveting tool, or a punch noting that only the first 2 rows of dimples at the front are formed into rivets on a DTCL. All other dimples should be impressed to form rivet heads.

TIP: If using a punch a piece of melamine make a good surface into which the rivets can be formed.

45) Remove 6x E5 - cab and passenger doors plus 2x E6 - baggage/guards' doors (TBSL only). To form the step, fold in half along the etched line noting you are folding *away* from the line, so the half etched line is on the outside of the fold and making sure the two halves are folded flat tight against each other. Run a bead of solder (or superglue) into the joint and file smooth.

46) Affix the solebars to the moulded solebars on the floor - with the formed rivet heads to the outside! Starting at the rear place the etch against the moulded solebar, tight against the underside of the floor edge and align the ends. Now dribble a small amount of superglue into the joint, just enough the hole the etch in place. Once it is secure and you're happy with its position, gently hold the etch away from the moulding and add more superglue and press back into place. Repeat along the whole length of the solebar. Remove any excess adhesive as necessary. NOTE: the solebar overlay is longer than the floor and the extra length is at the front under the cab.

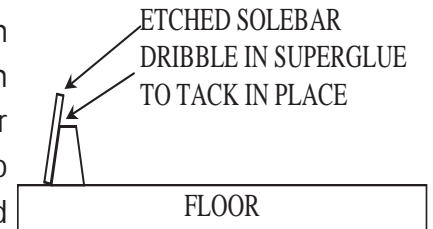

47) Affix the steps into the appropriate locating holes in the solebars. Unfortunately, the moulded solebar interferes with the locating holes so clip the mounting pins back until you can make the step sit close against the etched solebar. You will notice the solebar does not hang vertically so the steps have to be mounted at a slight angle to ensure they are horizontal when finished. A bit tricky to get right - I would recommend using low-melt solder for this as you can easily adjust the position and it will not affect the superglue holding the solebar in place.

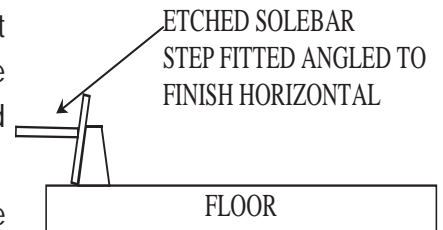

48.1) (DTCL) Find the solebar extensions C5 & C9. Clean and flash

and affix to the rear of the the brass solebar where they extend past the end of the floor. Align the casting with the top of the solebar and ensure it is flush with the end. The diagram (right) shows the idea as you'll build it, i.e upside down.

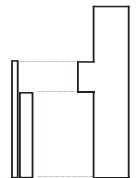
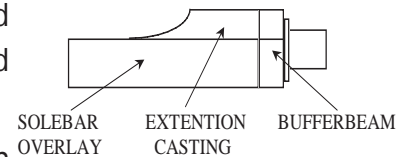

48.2) (OTHER UNITS) Fix the solebar extensions C5 & C9 to the back of the moulded solebars level with the end of the etched overlays at both ends. You will have to reduce the height and width of the casting slightly as it sits onto the floor moulding now - see right.

49) Locate the two aluminium bogie mounting turnings and prepare them by scoring their upper surface (the spigot faces downward when in use). Treat the mounting areas likewise. Use a strong adhesive fix the two round turned bogie mounts in the holes in the floor.

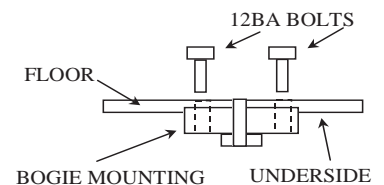

50) (Optional, but strongly recommended) To make a much stronger job of fixing the bogie pivots in place, you might consider a 'belt and braces' approach by adding a mechanical fixing to the mounting. Good results have been achieved by drilling two 1mm holes through the bogie mountings and floor (once the mounting has been fixed in place) either side of the bogie pivot bolt and tap 12BA. Now secure the bogie pivot in place by bolting down through the coach floor with short 12BA bolts (not supplied).

51) Remove the bufferbeams from their sprues together with the associated moulded stocks, clean flash, etc. and check the fit of the buffer shanks into the holes, open any tight holes to allow the buffers to slide easily. Check also that the coupling will go into the hole and stand vertically.

52) Remove the lamp irons (E29) from the fret, clean and fold the lamp iron as shown here using the etched dimples as a folding point, folding towards the dimple in the usual manner.

Should you decide to replace the buffers with the Oleo type as fitted to some units, we have provided suitable lamp irons as they are entirely different to ones used on our buffers.



53) Looking at the rear of the lamp iron, you will notice four half etched pads, apply superglue into the pads and affix to the four moulded buffer mounting posts on the bufferbeam. This guarantees the lamp iron etch will be square and properly aligned with the buffer hole.

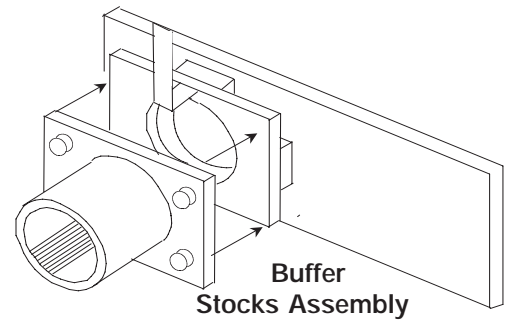

54) Apply a small amount of superglue to the rear of the buffer stock and, using a buffer shaft (or drill bit) as a guide, slide the stock into place on the brass lamp iron keeping the stock horizontal. Remove the buffer immediately.

55) (DTCL) Install the floor into the body and temporarily secure into position. Now fit the bufferbeam to the underside of the cab end, aligned with edges and butted against the ends of the solebars to ensure vertical squareness.

***TIP - Adding fillets of scrap styrene between the underside of the cab and the bufferbeam will greatly increase the security of the assembly. Aligning the fillets with the underframe ribs will ensure they will not interfere with fitting other details, or the couplings later.*

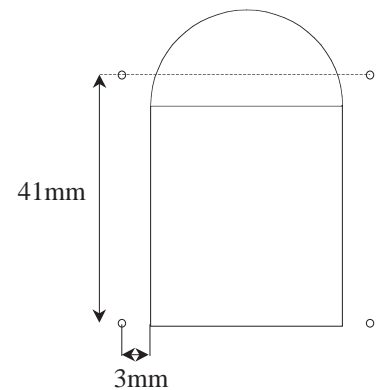

56) Non-Cab Bufferbeams - The bufferbeams should be fitted to the bottom of the end moulding. In this case, add a strengthening plate of scrap styrene to the rear and up onto the rear of the end body moulding. Add this plate after the floor has been removed, or you might have difficulty in getting it out! Now shape the end of the floor moulding to clear the strengthening plate until you can insert the floor easily. Don't forget to make a hole for the coupling hook.

ADDING THE REMAINING BODY DETAILS

57) Clean up any moulding marks from the corridor connection mounting plates (shown right) and clean up the edges. Mount the plates centrally on the non-cab ends of the unit about 2mm up from the bottom of the end moulding. This can be secured with plastic solvent.

58) Drill four holes in the moulded end 0.5mm diameter as shown right. These will be used to mount the corridor connection 'scissors', to be fitted during final assembly.

MU PLUGS

The MU plugs and sockets need a little explaining: the cabs have closed sockets and stowed cables, which are represented by C1c and C1d respectively. The rear has sockets with plugs inserted and cables in use (i.e. non-stowed), which are represented by C1a and C1b respectively.

*What is required to prepare the MU sockets depends on your preferences. If you want to connect the two unit together with MU 'cables' some method of attaching cables is necessary (these instructions), if not the castings can simply be fitted as is, with the exception of C1d which **should always be prepared as described.***

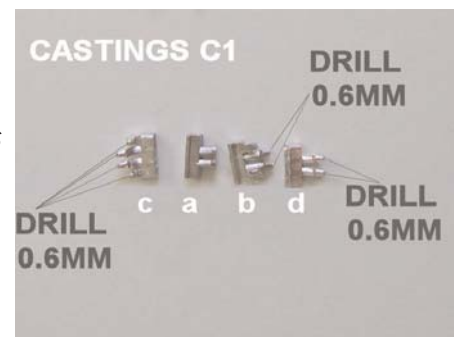

59.1) After cleaning up the castings square off the ends of the cable plugs (C1a, c and d) and make a pop mark in the ends.

59.2) Drill a small hole in the castings (0.6mm) just deep enough to secure a short length of 12

wire. On part C1a there are four holes to be drilled because the cables are depicted as stowed so form a pair of loops.

TIP: the short pieces of wire to be inserted into the holes are best left until final finishing as they tend to end up stabbing your fingers, catching on sleeves and cuffs and generally just getting in the way! Leave about 3mm of wire protruding onto which the cable tubes will be fitted.

59.3) Fit the castings to the underside of the bufferbeams with the outer edge of the casting aligned with the centre of the buffer, so the connections are set quite a way inboard, which is essential to be able to fit other details later on. The order of the casting are as follows when looking end on - C1a: cab left, C1b: cab right, C1c: non-cab left, C1d: non-cab right (the positions for C1c and C1d used at both ends of non-cab units). Remember you'll be working upside down so it's easy to get the order wrong!

The floor molding can now be removed from the body and the remaining details fitted to the body and underframe.

ADDITIONAL DETAILS

60) (DTCL) The vac pipes (C2) are fitted to the underside of the bufferbeam using the U-shape of the pipe as a saddle over the bufferbeam edge. They are about 6mm either side of the coupling hook. Bend the 'flexible' part of the pipe and the retainer so that they hang towards the adjacent buffer stock and glue to the bottom of the bufferbeam.

61) (DTCL) On the driver's side of the cab you will need to drill three 0.7mm dia. holes through the seam between the cab end and the body side moulding. These should be positioned to align with the other door hinges (approx. 6mm, 21mm and 38.5mm as measured from the bottom of the body). Also, drill holes for grab handle in front of the cab door on 2nd man's side, the holes should be 1mm from the edge of the door and 5mm apart centred on the cab T handle hole.

***Note - Door hinges are always on the left of the door.*

CREATING THE INTERIOR PARTITIONS

See Drawing 1 for layout of the interior of the two cars including the partitions as described in the following steps. Study the photos of the interior details (Seats 1 to 6 - Cl. 108 model) to get a clearer idea of what is now being described remembering these images are of a class 108 so show the 'idea' only.

62.1) Carefully remove the cab partition E45 and the full width saloon partition E44 from the fret and remove the tabs. Fold the bottom three sections along the half etched lines, making each fold towards the half etch. You should now have two short tabs and long central tab folded at 90° in opposite directions and have a partition that can be stood up, if not you've folded it up wrong! Images: *Cab Partition Bends & Cab Partition Bottom* (Cl. 108 model).

Part E45 is used in the non-cab units as the first saloon partition/vestibule wall. I'm not sure if it should have windows, or not, however no passengers have yet complained if it is wrong!

62.2) Check the fit of the partition inside the body and trim as necessary to achieve a sensible fit.

62.3) Take four false floor holders E36 and affix (solder/glue) into the slots at the bottom of the partitions so that projection forms a slot with the outer folds at the bottom of the cab partition. Image: *Partition with floor supports* (Cl. 108 model).

63.1) (DTCL) Cut two styrene cab floors 14mm x 55.0mm (check your body width) and fit to 13

the longer central folded base of the cab partitions to form a cab floor. Fit into position adjusting the various items as appropriate.

63.2) (DTCL) Clean and fit the cab seat (C20) to the short cab floor positioned to roughly align with the curved recess in the cab desk and its back just clear of the partition. Also, clean and fit the AWS box/2nd man's seat (C35). This goes to the immediate left of the etched cab door with the seat portion (the lower step) nearest the door. Image: *Cab Partition.JPG*

64) We have made some small moulding that can be fitted into the roof channel at an appropriate place to ensure the partitions stand vertical, especially the cab partition. These can be fitted now, or painted the same colour as the roof and fitted with the interior components. Unfortunately they don't work with the half partitions because the partition doesn't reach them.

65) Remove the saloon half partitions (E42 & E43) from the fret and clean off the tabs. On the DMBS you will only need four of the six. Fold the bottom parts in the same manner as the full width partitions and fit the false floor holders (E36) as before. Partition E46 should be prepared in the same way, but without the false floor holder - not required for the TBSL.

66) Locate the moulded floor stretchers, clean off any flash and affix across the body in line with the passenger doors and at the front and rear of the body. The DTCL and TBSL only have three as the front of the floor is supported by the cab on the DTCL and the rear on has a long bolt to the roof inside the baggage area on the TBSL.

67) (TBSL) The final partition is created from the moulded ABS divider. This will need trimming as necessary to fit immediately behind the last passenger door. Once prepared this partition can be permanently glued into position against the relevant body stretcher.

That just about covers the body at this stage.

UNDERFRAME DETAILS

68) Fold the mounting bases of the brake hangers (E31). Assemble the brake levers (E34) onto short lengths (45mm) of brass rod - don't fix yet. Drill a 0.9mm dia. hole into the centre of the brake cylinders and insert a short piece of 0.9mm wire as a pull rod.

69) One brake hanger mounts butt up to the inside face of the solebar and the other sits on the floor at the side of the moulded rib, so they go about $\frac{2}{3}$ rds the way across the floor. Insert the brake pivot rod into the mounting and secure in place. Once the brake hangers are in place, mount the brake cylinders so that the pull rods coincide with the brake levers. See diagram right for basic idea.

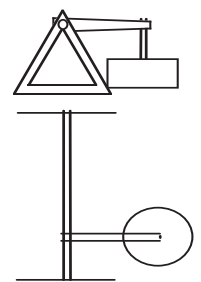

70) Assemble the vac tank (C21 3 parts) and the fuel tank (C20a & C20b), I don't think you can put these together incorrectly (please don't try and prove me wrong!). The vac tank mountings will need trimming to sit between the floor ribs.

71) Mount the vac tank onto the floor and fuel tank on top of the ribs with the fuel fillers angled down to the underside of the solebars.

72) Mount the space heaters so that the angled duct sits into the solebar/floor joint. It will only go one way round as the angled duct is angled towards the outside of the floor.

73) With C12 and C13 in place make up the conduit by joining two conduits on top of C13 and then secure the ends to the floor. You'll notice on the images of the demo model that there's a conduit going down to the floor between the two castings - WRONG - I got carried away!

74) (DTCL) Fit the speedo drive casting (C32) to the solebar mounting (the bit the hangs down!) The casting is the small square items on the sprue.

75) Insert the floor into place and drill holes to secure the floor to the body using the various body stretchers.

ETCHED WINDOW FRAMES. READ ALL THE STEPS BEFORE PROCEEDING.

The window frames do not have an etch number. There are 3 types of frame: large, small and toilet so there shouldn't be too much confusion there.

78) Carefully cut the window frames from the etch and file the tags smooth taking care not to file into the frame itself. Fit the toilet window vent centrally on its backing prior to frame fitment. DO NOT fold out the central ventilator opening tabs of the main windows until the window frames are fitted.

79) Check that the frames fit the openings (dry run) - the openings should be very slightly larger than the locating lip on the reverse of the window frame.

TIP: Before installing the etched window frames check the fit of the window glazing within the openings. Carefully file the edges of the glazing panels until they fit snugly, but not sloppy nor tight.

Using a slower acting superglue may be preferable when fitting the window frames as it would allow you more time to align the window frame before the glue sets.

80) Apply a small amount of superglue directly to the rear frame at the top only. Position the top of the frame into the opening and allow to set. Now, using a small piece of flat material roughly the width of the window frame, gently press the bottom into place and apply glue to the frame/window opening joint from the inside (this is most easily achieved with an old craft knife blade dipped in superglue). Once the frame is secure apply more glue to the side joints as appropriate.

81) Remove any excess glue after glue has set using a glass fibre pen, or fine abrasive paper (glass fibre pen found to be best for this).

82) Once all is set and clean of excess glue, fold the central ventilator tabs outward. This is best done with two pairs of small pliers both at the same time: gently grip each tab and fold outwards. Once the tabs have moved from a flat orientation use a single pair of pliers and close the tabs with a squashing action, there should be a gap between the ends of the two tabs when fully folded.

83) Remove the body side grille (E23) for the etch and clean up as required and add a slight bevel to the edges. It is fitted centrally beneath the small window adjacent to the passenger access door on the 2nd man side of the unit about 1.5mm below the window frame. There is only one grille fitted. Image: *POWER CAR UNDERFLOOR 2.JPG*

84) Fit the door gutters next (E37 (long) & E38 (short)). The long gutters are for the double baggage/guard's doors on the TBSL. Drill two (or three for the long gutters) at the top of the door scribe marks. If you're having trouble determining exactly where that is after all the sanding &

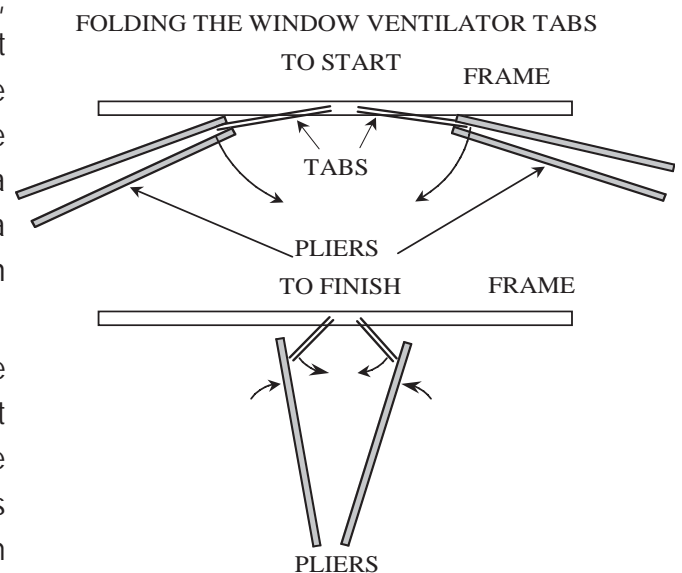

filling, take a measurement from the bottom of the body to where the body joins the cab roof above a cab door as that's easy to see. All gutters go along that line. Simply press the gutters into the holes and use superglue to secure in place applied from the inside.

FINISHING

With the main construction now complete it is time to prepare the model for painting. Whilst this consists of mainly cleaning and washing of all the parts, it also gives you another opportunity to check the security of the various fittings. Anything that cannot stand cleaning will probably not withstand long-term use, so it's better to have bits falling off now than later - refit as required!

INTERNAL DETAILS

85.1) Remove the appropriate number of seats from the sprues and prepare them by removing the ejection pin marks (small round marks on seat back) and moulding feed joints.

85.2) To form the seat, flex the moulding until the joint between the base and seat back shows a thin white line. Apply solvent, or superglue to the joint holding together briefly to prevent the back from initially springing apart.

85.3) The arm rests can be added to create first class type seats if required.

85.4) You will also require a single seat creating by cutting a twin seat in half. Re-model the seat back to make it more realistic as a single seat rather than a cut-down double seat.

86) To mount the seats cut a set of false floors onto which to mount the seats. It is better for you to determine the exact lengths required in your model, but the following dimensions are an appropriate starting point:

20mm wide for twin seats & 26mm wide for triple seats- 95mm (front saloons); 145mm (centre saloons both units); 95mm (rear saloon). I tend to cut them too long and trim to exact length when actually doing the final assembly.

Use the seating plan to create the following floors:

87) Fix a half partition to each end of the centre saloon floors ensuring the curved edge of both partitionss are towards the outside of the carriage.

88) Fix two half partitions to one end of each rear saloon floor, again keeping the curved edge towards the outside of the carriage.

89) The remaining saloon partition E46 does not fit onto a false floor directly, but is affixed directly to the inside of the body behind the last seat immediately after the last saloon window (this is across from the toilet cubical) - fit after painting.

90) Paint the seating and attach to the floors

91) Fold the toilet compartment (E29) to form an 'L' shape. Check the cubicle will fit in place and still allow the floor to be fitted. Paint and fit toilet cubicle as appropriate.

Fitting the toilet cubical above the rear body stretcher (if fitted) allows the false floor to be extended right to the end of the unit and so give you something to tape the floor to until the main floor is in place.

FINAL ASSEMBLY

92) (DTCL) Find the windscreens you put in a safe place some time ago and fit using small amounts of adhesive - we recommend using RC Modellers Glue (canopy glue). Dilute a small

amount with water and apply from the inside with a small brush to the edge of the glazing allowing capillary action to draw the liquid into the joint.

93) Install the glazing into the window openings from inside the body, remember to 'frost' the toilet window by rubbing the inside face with 800 grit abrasive paper (wet). Fit dry and secure in place by running dilute canopy glue around the edges with a small brush.

94) Fit the door windows.

95) (DTCL) Fit the control desks.

96) Check the fit of the buffers in the stocks once again for a sliding fit, adjust as necessary. Fit the front buffers and springs into the stocks and secure in place with a wire pin. NOTE: the rear buffers will need to be able to be removed to be able to gain access to the inside of the model so maybe a split pin is a better option, or something soft that can be reinserted and bent to retain later.

97.1) (DTCL) Fit the cab partition in place (you may wish to install a driver in one end at this stage) and the other partitions with doors making sure they are stood vertical.

97.2) (Non-Cab Units) Fit the cab partition in place adjacent to the first door, this partition is best fixed permanently in place as it makes fitting the false floors easier and insert the other partitions with doors making sure they are stood vertical.

98) Carefully negotiate the false floors into position and secure - we used tape to hold things together until the floor is in position.

99) Slot the centre and rear saloon floors into place and secure as before.

100) Assemble the underframes onto the appropriate bodies and secure in place.

101) Mount the bogies and ensure they are free to rotate. (DTCL) The speedo drives can be connected to the solebar units using the silicon rubber tubing supplied. Do not make the link too short as it will restrict bogie movement, however too long and it may snag on track side components. Start with about 35mm and work back from there until it looks right.

102) (DTCL) Bend the wiper 'blades' 90° to the arms (E17) so that they present a blade edge to the windscreen ensuring you create left and right handed wipers (should you decide to fit wipers to both screens). A small dimple on the rear near the blade will assist bending without distorting arm. Solder a piece of 0.4mm wire through the mounting holes in the arms, paint black and fix into the holes previously drilled above the upper edges of the windscreen beading. The wipers are intended to be in the parked positions, which is up against the outer edges of the windscreens.

103) Fit all door 'T' handles and grab handles E9. It should also be noted the guard's door has a special etched cranked door handle (E39) and the baggage doors (TBSL) E40.

104) Fix the corridor connections and scissors to the rear of the units.

105) (DTCL) Add appropriate headcodes and fit the previously cut glazing and secure the outer headcode cover in place. Repeat for the destination box above the windscreen.

106) (DTCL) Add light lenses to the cab lights a appropriate.

We hope you have enjoyed building this kit and welcome your comments. You will notice you have quite a few etched parts left over, the reason for this is that for the units with the most items it was necessary to produce a secondary etch (sheet 2A). However that meant that every kit has all the items required for all units otherwise we would have had to make yet another etch. Obviously, nothing

that appertains to the cab will be used on a non-driving trailer. This might seem too obvious to mention, but we have been asked to say what isn't required, so there you have it

SHAWN KAY AUGUST 2016

NOTES

DRAWING1

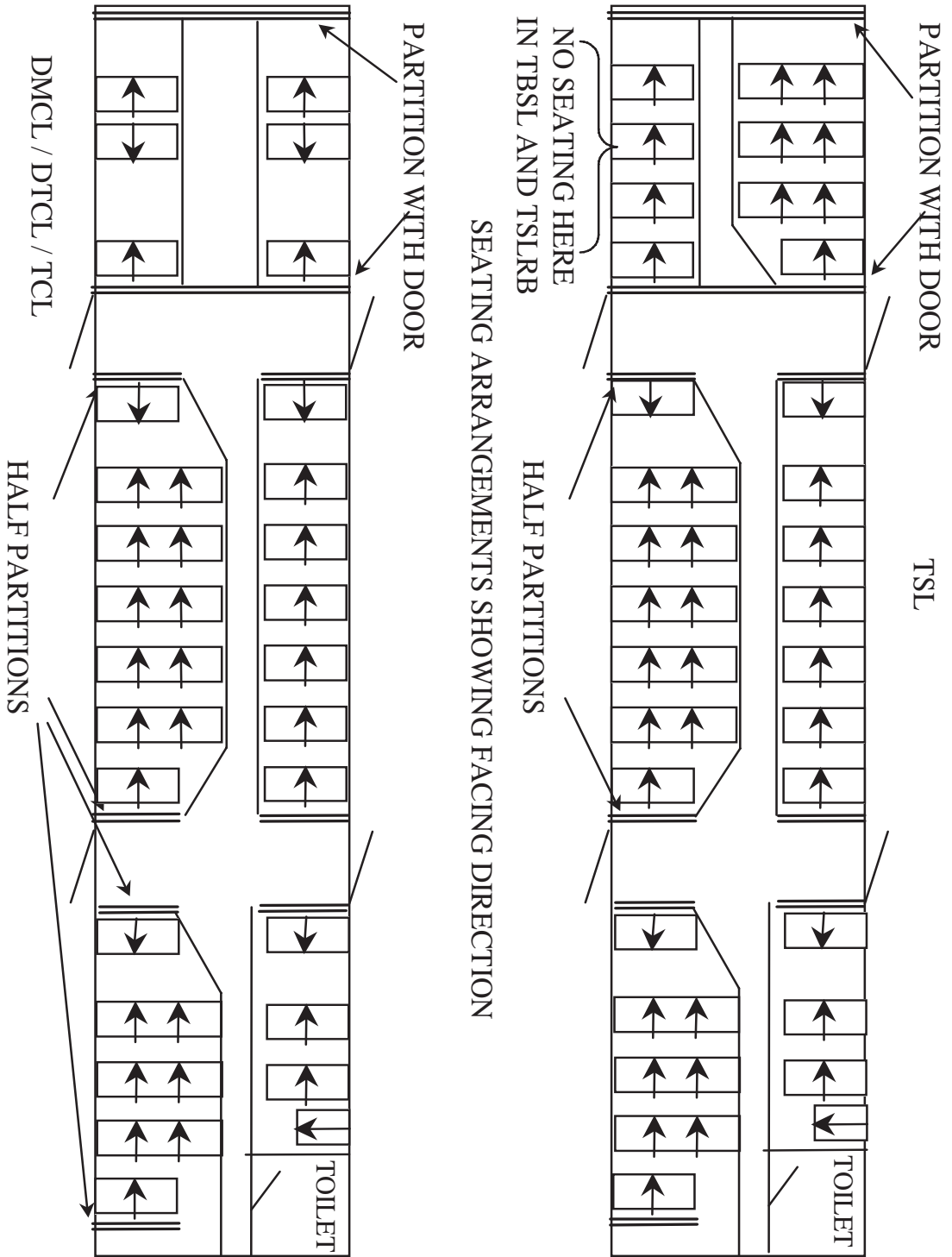

Trailer Car Underframe Layout

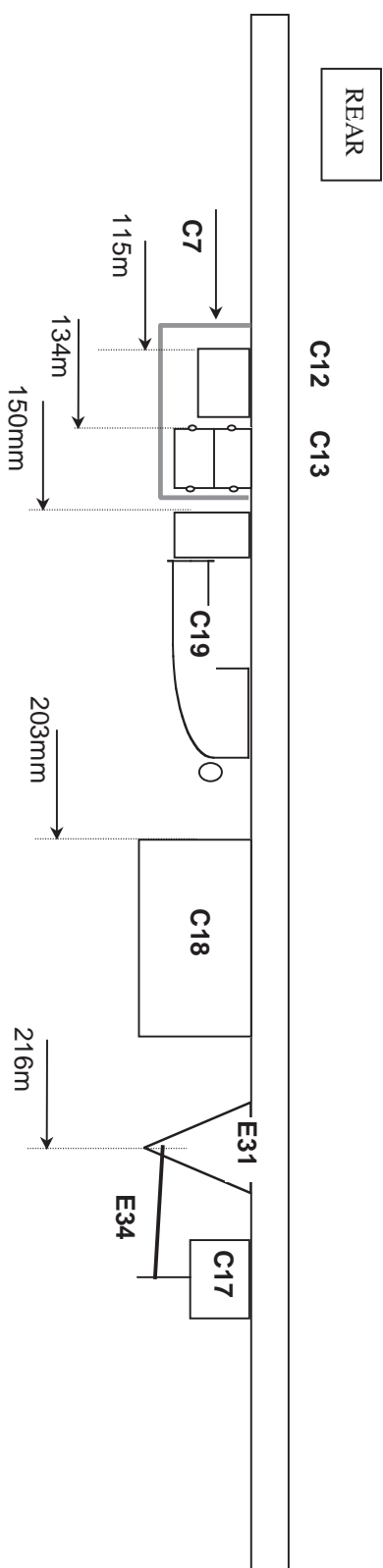
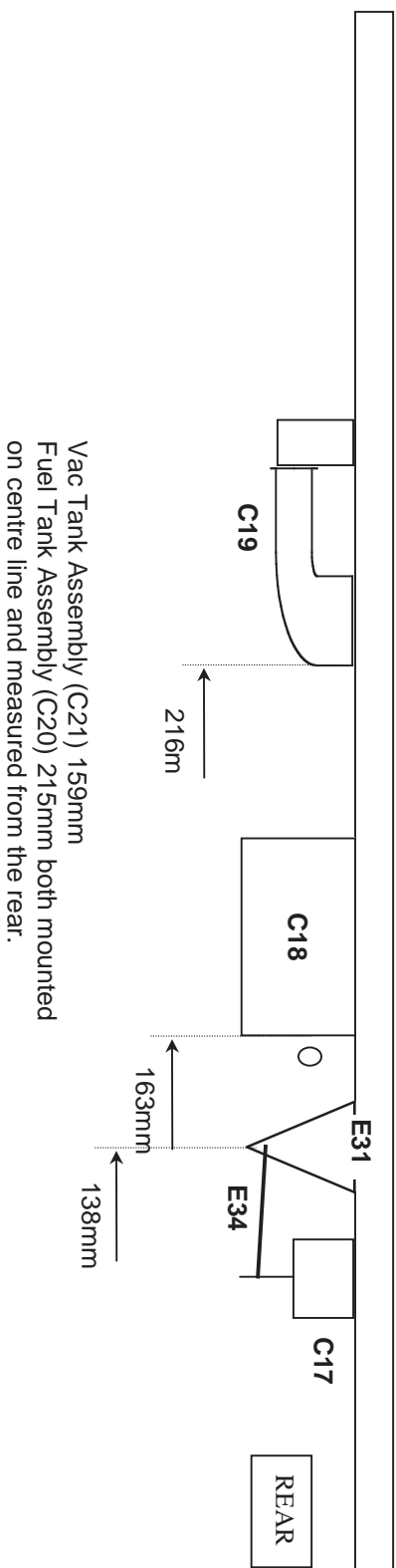

DTCL & NON-DRIVING TRAILER CARS CASTINGS

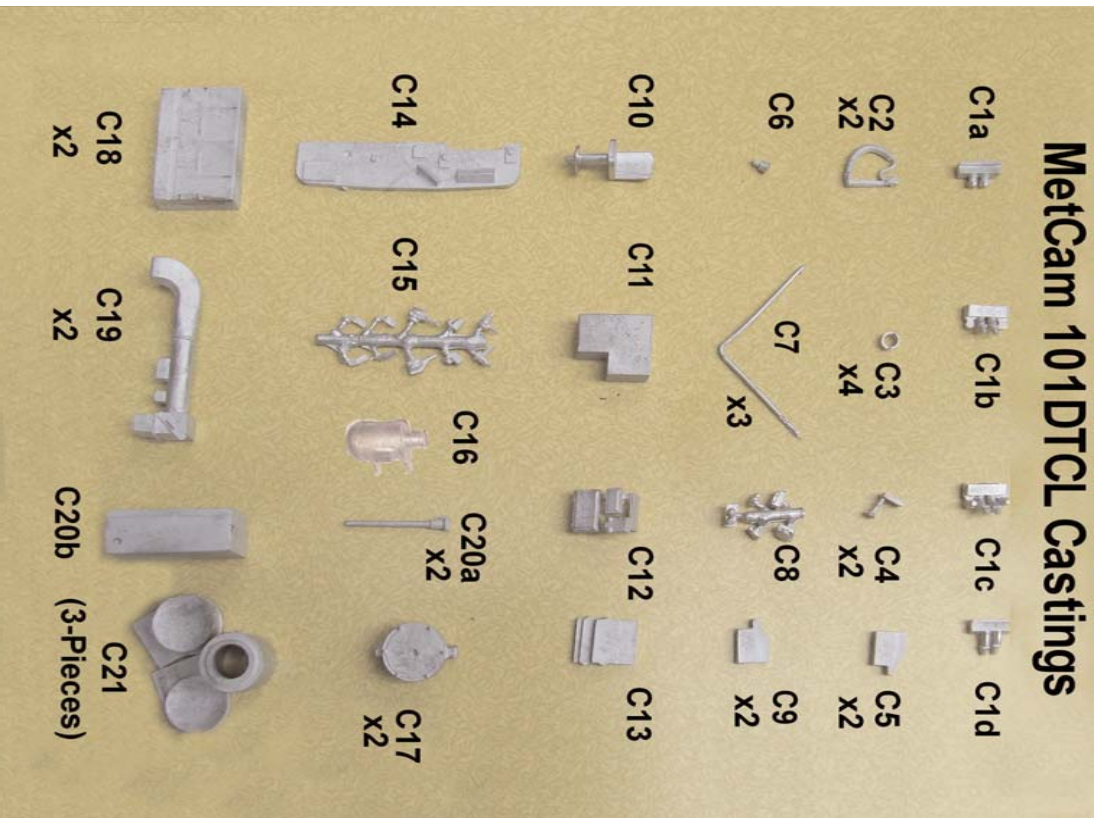

| | | |
|------|----|---------------------------------------|
| C1a | 1x | MU CONNECTORS CLOSED STOWED |
| C1b | 1x | MU CONNECTORS CLOSED |
| C1c | 1x | MU CONNECTORS OPEN w/STOWAGE |
| C1d | 1x | MU CONNECTORS OPEN |
| C2 | 2x | VAC PIPES - NEW |
| C3 | 4x | CAB LAMP SURROUNDS |
| C4 | 2x | SINGLE HORNS |
| C5 | 2x | SOLEBAR EXTENSION R/H no/EXHAUST STUB |
| C6 | 1x | ROOF WATER FILLER |
| C7 | 3x | CONDUITS |
| C8 | 1x | SPEEDO SENDER/RECEIVER SPRUE |
| C9 | 2x | SOLEBAR EXTENSION L/H no/EXHAUST STUB |
| C10 | 1x | CAB DRIVER SEAT |
| C11 | 1x | AWS 2nd MAN SEAT |
| C12 | 1x | STEPPED EQUIPMENT BOX |
| C13 | 1x | STEPPED EQUIPMENT BOX |
| C14 | 1x | CAB DESK |
| C15 | 1x | CAB DESK CONTROL DETAILS |
| C16 | 1x | DYNAMO |
| C17 | 2x | BRAKE CHAMBER |
| C18 | 2x | BATTERY BOX |
| C19 | 1x | LONG SPACE HEATER |
| C20a | 2x | FUEL TANK FILLER |
| C20b | 1x | FUEL TANK |
| C21 | 1x | VAC TANK (3-PIECES) |

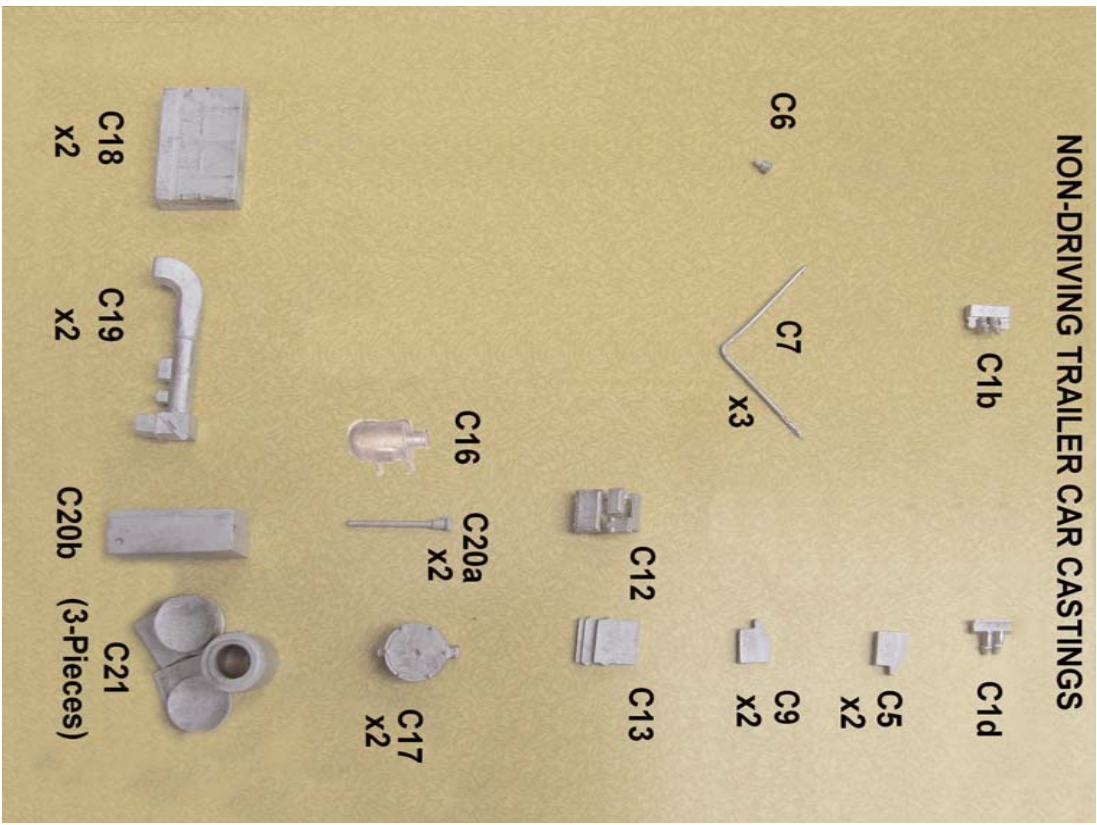

NON-DRIVING TRAILER CAR CASTINGS

| | | |
|------|-----|---------------------------------------|
| C1a | N/A | |
| C1b | N/A | |
| C1c | 2x | MU CONNECTORS OPEN w/STOWAGE |
| C1d | 2x | MU CONNECTORS OPEN |
| C2 | N/A | |
| C3 | N/A | |
| C4 | N/A | |
| C5 | 2x | SOLEBAR EXTENSION R/H no/EXHAUST STUB |
| C6 | 1x | ROOF WATER FILLER |
| C7 | 3x | CONDUITS |
| C8 | N/A | |
| C9 | 2x | SOLEBAR EXTENSION L/H no/EXHAUST STUB |
| C10 | N/A | |
| C11 | N/A | |
| C12 | 1x | STEPPED EQUIPMENT BOX |
| C13 | 1x | STEPPED EQUIPMENT BOX |
| C14 | N/A | |
| C15 | N/A | |
| C16 | 1x | DYNAMO |
| C17 | 2x | BRAKE CHAMBER |
| C18 | 2x | BATTERY BOX |
| C19 | 1x | LONG SPACE HEATER |
| C20a | 2x | FUEL TANK FILLER |
| C20b | 1x | FUEL TANK |
| C21 | 1x | VAC TANK (3-PIECES) |

ETCHED PARTS SHEET1

Key:

- E1) ROOF PANEL
- E2) SOLEBAR BRAKE CARS
- E3) SOLEBAR NON-BRAKE CARS
- E4) BOGIE PIVOT RETAINERS
- E5) DOOR STEPS - SHORT
- E6) DOOR STEPS - LONG

CONTROL DESK DETAILS

The very basic diagram below shows the layout of the control panel castings. The large round circle is the etched brake wheel E32.

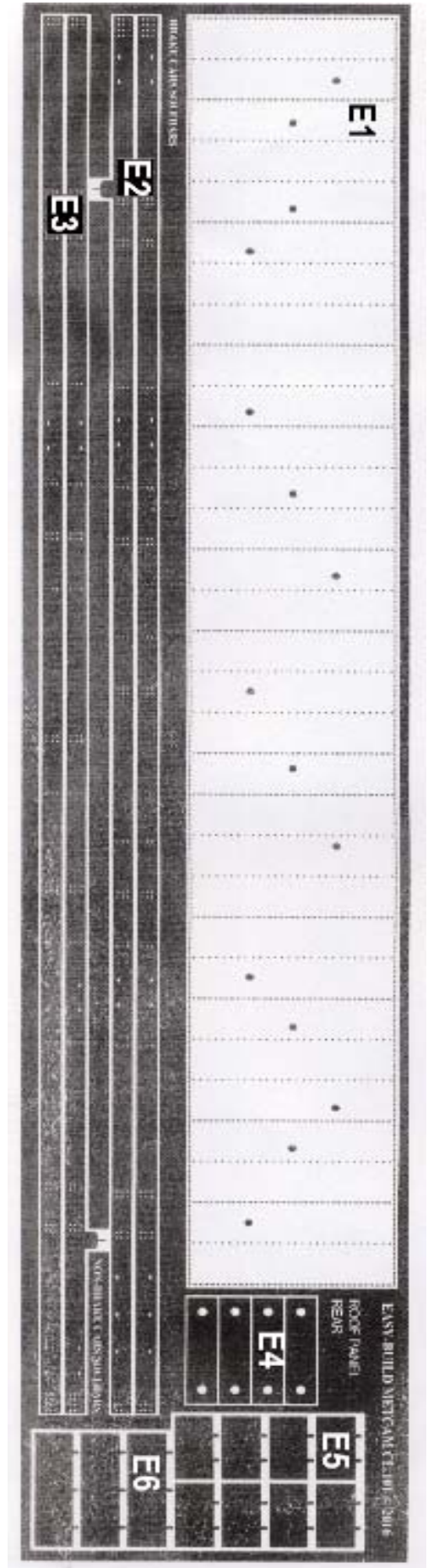

ETCHED PARTS SHEET2 & 2A

Key:

- E7) TOILET COMPARTMENT
- E8) N/A
- E9) DOOR GRAB HANDLES
- E10) SLIDING DOOR TOP RAILS
- E11) N/A
- E12) SLIDING DOOR HANDLES
- E13) N/A
- E14) CAB SWITCH PANEL
- E15) N/A
- E16) DESTINATION BOX FRAME
- E17) WIPER BLADES L/H - R/H
- E18) CONTROL DESK SUPPORT
- E19) HEADCODE BOX OUTER FRAME
- E20) HEADCODE BOX INNER FRAME
- E21) CAB WINDOW FRAME (OUTER)
- E22) CAB WINDOW FRAME (CENTRE)
- E23) BODY SIDE GRILLE
- E24) HINGE 'BUTTERFLIES'
- E25) HINGE PINS (LONG AND SHORT)
- E26) BOGIE STEP HANGERS
- E27) BOGIE CHANNEL (GUARD IRONS)
- E28) BOGIE END CHANNEL (PLAIN)
- E29) LAMP IRONS
- E30) BOGIE SPEEDO MOUNTING
- E31) BRAKE PIVOT HANGER
- E32) BRAKE WHEELS
- E33) CORRIDOR CON SCISSORS
- E34) BRAKE SHAFT LEVERS - LONG
- E35) LAMP IRONS - OLEO TYPE
- E36) FALSE FLOOR HOLDER
- E37) DOOR GUTTER (LONG)
- E38) DOOR GUTTER (SHORT)
- E39) GUARD'S DOOR HANDLES
- E40) BAGGAGE DOOR HANDLES
- E41) DYNAMO MOUNTING
- E42) SALOON PARTITION L/H
- E43) SALOON PARTITION R/H
- E44) SALOON PARTITION (FULL WIDTH)
- E45) CAB PARTITION
- E46) SALOON PARTITION LUGGAGE AREA
- E47) BOGIE GUARD IRONS L/H & R/H

