

"EASY-BUILD" CRAVENS CLASS 129 ASSEMBLY INSTRUCTIONS.

PLEASE READ THESE INSTRUCTIONS FULLY BEFORE PROCEEDING WITH ASSEMBLY AS MORE THAN ONE ORDER OF CONSTRUCTION MAY BE USED.

SAFETY FIRST! IN ORDER TO CONSTRUCT THIS MODEL YOU WILL BE USING VOLATILE SOLVENTS, ALWAYS FOLLOW THE MANUFACTURERS INSTRUCTIONS AND ENSURE ADEQUATE VENTILATION. YOU WILL ALSO REQUIRE SHARP TOOLS AND THE EDGES OF THE ETCHED PARTS CAN BE VERY SHARP SO TAKE CARE WHEN HANDLING. WORK STEADILY AND SAFELY AT ALL TIMES.

INTRODUCTION

The general idea for assembly is to construct a box with a removable floor. This enables the roof to be permanently fixed and any joint lines, etc. removed by filling and sanding. In order to get the most from your kit we recommend you read these instructions in full prior to commencing construction making notes as to any assembly options, or changes to the suggested order you think would suit your method of building better. However, we suggest you do adhere to the order of construction as we know it works! Although the photographs of a prototype on the photo-reference CD-ROM depict a preserved two-car passenger unit, they do show the main (externally visible) underframe details clearly though some items of equipment on the single car units were in different locations. For final detailing, working with both the instruction drawings and the photos will produce a very accurate representation of the underframe components.

BEFORE STARTING CONSTRUCTION WASH ALL MOULDED PARTS, INCLUDING THE WINDOW GLAZING TO REMOVE MOULDING AND MACHINING LUBRICANTS.

PREPARING THE SIDES

1) There are three filler tank recesses on each vehicle side, carefully open these out to form oval holes - do not stray outside the machined outline. Once satisfied with the size and shape carefully file the bottom of the opening flat. Fit the copper rivet into Casting 10 to represent the filler cap then attach at the rear of the cut out. Don't forget that the sides have curved profile so some light filing may be required to get a snug fit. The lower position castings are the fuel fillers and upper filler is water (see Filler back casting.jpeg and Filler casting in place.jpeg). Whilst working here, remove a section (about 7mm) of the inner body rib in line with the fuel fillers. This is necessary to allow the filler castings to be located properly.

2) Make a small cut in the inner rib 15mm from each end. The cut should go down the surface of the inner side, but no deeper and needs to be about 0.5mm wide. This is to allow the driver's compartment wall to be fitted later on.

3) With the exception of the guard's compartment, all doors have externally fitted hinges. You will notice that the mouldings for the sides are identical, except for the fact the the guard's door do not have any pre-marked external hinge locations. With both sides laid flat and the outer surface up, the guard's compartment doors are the first set of double doors on the left hand side of one body moulding and the first set of double doors on the right hand side on the other. The guard's door is depicted by cutting off the bottom of the windowed door level

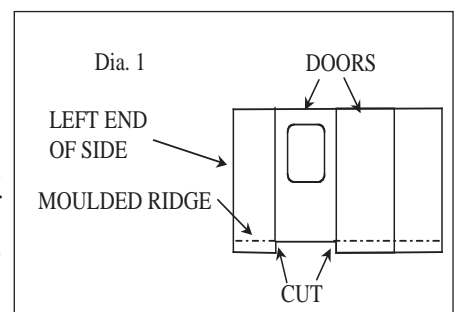

with the bottom of rib moulded on the inside of the body to the full width of the door. **DO NOT CUT OFF THE BOTTOM OF THE ADJOINING DOOR!**

4) Drill through all the pre-marked holes in the sides 0.7mm dia. for door hinges, handles and bump-stops. There are no pre-marked drilling points for the guard's doors. Drill 0.7mm holes for cab door grab-irons. If modelling a blue period unit, drill two 0.7mm dia. holes 3mm and 10mm from bottom of sides in line with door commode handle mounting holes for a short handrail.

5) Check the depth of score lines at the door positions and deepen if you prefer. Carefully remove raised burr from door opening scores, work slowly and re-open score marks as necessary until desired effect has been achieved.

6) Check the ends of the side mouldings for cutting burrs removing as necessary ensuring the edge remains square and true, i.e. don't be too enthusiastic with the knife!

***TIP - Use a gentle scraping action followed by 1200 wet-n-dry (wet is best) for these two operations. Alternatively, a small chisel can be used to shave off the burrs. Old flat needle files can be ground into chisels and are ideal for this purpose.*

7) Check the fit of the sides against the cab ends. The sides should be level with the bottom edge of the cab. It is necessary to create a small rebate (about 5.5mm long x 1mm deep) at the top edge where it meets the underside of the roof. The upper corner of the end, where the roof meets the edge of the door opening has a small radius (a production process aid) and will also need to be filed square in order to accurately create the rebate in the sides. Don't forget both ends have to fit both sides!

***TIP- Number the ends and sides on the inner surfaces to ensure each side mates with it's appropriate end later on.*

8) Now would be a good time to give the whole side a rub down with 1200 grit wet & dry. At this stage you can go over any of the previous body preparation operations quite easily until you are fully satisfied with the results. Once the door hinges are in place it is much more difficult to do so.

DO NOT ASSEMBLE THE SIDES AND ENDS AT THIS STAGE.

9) You will now require 36 etched door hinge assemblies (E20 24 long and 12 short). Each hinge piece is pushed through a butterfly shaped backing piece (E21) then glued into the hole in the side trapping the butterfly with the hinge. The short hinges are for the centre hinge locations with a long hinge top and bottom. Remember - the guard's doors open inward and so has no visible external hinges.

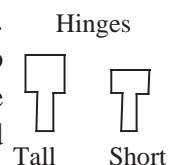

10) Using the 1mm micro rod 'plug' the holes in the doors centres and those to the left and right of the doors to represent the doorstops. Note, when drilling the holes the size stated for the door bump-stops was 0.7mm, this enables other solutions to be considered for this detail. If you do use the micro rod open out the holes accordingly. The stops should be trimmed so that they protrude not more than 1mm from the sides. Note doorstops are not fitted to all doors.

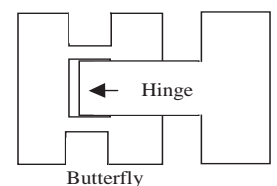

***TIP - To ensure all the bump stops are trimmed to the same length: drill a 1mm dia. hole in a piece of 1mm (40 thou) thick scrap styrene (or other sheet material). Place the scrap styrene over the bump stop so that it protrudes through the hole and gently pare back the excess with a sharp knife, followed by a fine file. Remove the styrene and, once all bump stops have been so treated, give them all a gentle rub over with fine abrasive paper to round the edges slightly.*

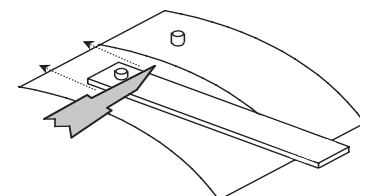

That completes the sides for now.

ROOF PREP

You will notice your roof has a curve due to the moulding process this is useful when fitted as it

ensures the roof is a tight fit in the centre of your coach.

11) Clean off any burrs of plastic then put a strip of masking tape down the centre of your roof onto which you can mark the positions of roof vents etc. from the sketch provided.

12) Drill your marked positions 2.0mm to accept the roof vents and remove tape (SEE Drawing2).

NOTE, the sketch of roof vent positions is scaled from various photographs and so absolute accuracy cannot be guaranteed. If you have more accurate information to hand please tell us and we will update our instructions.

13) Whilst you can now fit the roof vents and exhaust pipes casting (casting 6), you might prefer to leave these until the roof, sides and ends are assembled so that filling and shaping of the joints can be undertaken without fear of damaging the details.

FLOOR PREP

14) Clean off burrs due to the machining processes.

15) Remove the partly cut out motor mount area and clean up the edges of the cut as necessary.

16) Locate the two aluminium bogie mounting turnings and prepare them by scoring their upper (flat) surface (the spigot hangs down in order to provide the correct body ride height). Treat the mounting areas likewise.

17) Using a strong adhesive fix the two round turned bogie mounts in the circles provided.

NOTE: See Modification To Floor on page 17 for details of a small modification necessary to allow the motor bogie to have full movement.

18) (OPTIONAL) It has come to our attention that the bogie mounting bosses have occasionally come adrift even when prepared correctly. You may prefer to strengthen the assembly by adding two 12BA bolts to the assembly (see Dia. 2). This is best achieved after the boss has been glued in place. Drill holes 1.1mm dia. and tap 12BA through both the floor and boss. Add bolts and file off any thread protruding from the underside of the boss.

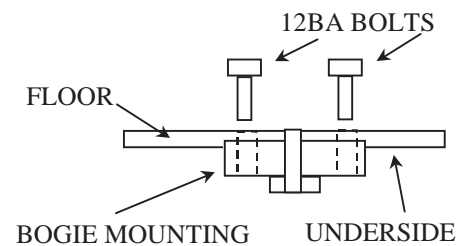

ENDS PREP

19) Ensure the corners under the roof at the door top positions have been filed as noted above (step 7) and remove any moulding flash from window openings, etc..

20) Drill two 0.4mm dia. holes in the centre of each window directly above the upper window beading to mount the windscreen wipers (E1) later (see craven end 2.jpeg).

21) Cut glazing to fit the windscreens. Start with pieces 20.5mm x 23.5mm and then round the corners sufficiently to clear the moulded inside corners of the glazing recess inside the cab. Do this now as it is very difficult to do once the body has been assembled. DO NOT FIT just keep the glazing safe for now.

NOTE:If you intend to illuminate the end lights these should now be drilled out as required. No provision is made for this in the kit and so it is up to the builder to determine how best to achieve the installation.

22) Fold cab control desk support E4 along the first half etch, i.e. nearest the end, and add mid support E4 into the centre half etch. Add desk top and check for fit inside cab.

23) Looking at the end from the front, drill holes in the LEFT cab wall ONLY for the commode handles at 15mm and 20mm. and short handrail (blue livery only) at 3mm and 10mm, 1mm from the edge (where the door adjoins later).

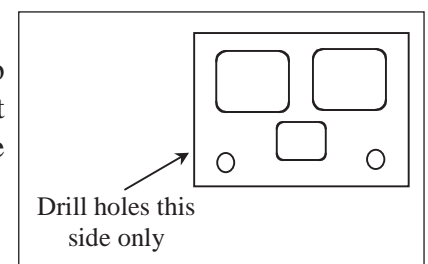

BODY ASSEMBLY - NOW FOR THE FUN PART!

Whilst the solvents used to assemble the components evaporate very quickly the joints they produce take considerably longer to achieve maximum strength. DO NOT RUSH THESE NEXT STEPS. Leaving ample time for the joints to harden is essential and you will be rewarded for your patience by not having unsound joints later on.

24) Fix a cab end to the opposite ends of each side to each end to form an 'L' shape half box as shown right. Assuming care was taken when preparing the ends and sides (including identifying which end and sides adjoin each other) your sides will be level at the bottom. Ensure the outside faces of the sides are a good match, in profile, to the outside of the ends at the door line.

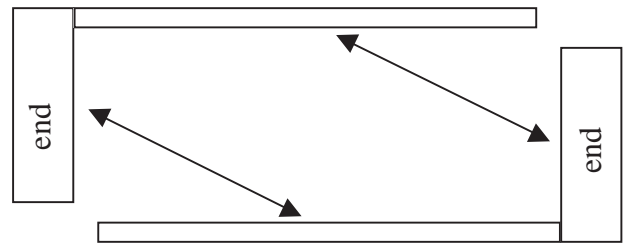

***TIP - Working on a glass sheet will aid accurate bottom alignment of the sides and ends.*

25) Assemble the two half boxes again using a flat surface to aid alignment. Use the roof to check the ends are correctly aligned. The box may twist a little to during this process due to the flexible nature of the materials, but do not worry unduly as the roof will bring everything back in line later. Be very careful when handling the 'box' as at this stage it is a bit floppy and can easily be damaged.

LEAVE TO SET HARD AND BUILD THE BOGIES

The instructions here initially refer to an un-powered bogie. Note also that the bogie sprues contain parts that are not intended for the DMU so please refer to the illustrations to identify the appropriate parts to use.

26) Remove the bogie frame stretcher plate from the casting sprue and cut off the ends level with the inside edge of the moulded angle. Clean up and square off as necessary.

27) Push brass bearings into axle holes making sure they are an easy sliding fit, if necessary clean hole with a 2.5mm drill. Do not fix in position as adjustment is made later.

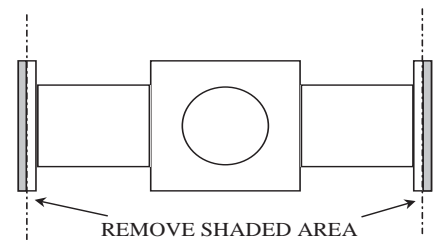

28) Using a pin, add a tiny drop of oil, NOT WD 40, into the bearing surface.

29) Place two non-driving axles in the bearings of one side frame and ensuring correct orientation of bogie frame stretcher plate i.e. reinforcing cross members down, assemble the side frame to the frame stretcher.

30) Once the first frame is reasonably firm assemble second side frame onto frame stretcher in the same manner. When the side frames are secure enough to hold themselves in place, make certain all is square and in line, minor adjustments can still be made at this stage by applying more solvent to soften the joints and adjusting as required. Note: wheels should be a loose fit in the bearings at this stage. Leave the bogie to set for at least 1 hour, 2 is better.

31) With the joints set hard we can now set the axle bearings:

31.1) Centralise the wheelset and insert a thin piece of card between each wheel and the side frame to prevent lateral movement.

NOTE: Do not over-pack the wheelsets as this might cause the sides to spring when you remove the card later resulting in stiff wheel movement.

31.2) Push in the bearings from the outside until the bearings connect with the axle ends.

31.3) When satisfied that the bearings are (just) against the pinpoint ends fill the bearing hole with the 2.5mm sprue supplied, or micro-rod (not supplied) and fix with liquid solvent from the outside and leave to harden.

31.4) When set, remove spacing card and trim any excess rod flush with axle box face

32) There are two different types of axlebox covers supplied in the kit, use the slightly domed Timken covers for the Cravens unit. With the bogie facing forwards, i.e the front away from you, the front left axle box of each bogie has a speedo drive attached so do not fit a cover to that axlebox. (see Bogie speedo drive.jpeg)

33) Remove the bogie pivot mounting from the casting sprue and remove any flash. Test the bogie pivot bolt is an easy sliding fit in the mounting hole. If tight, open the slightly with a 3.5mm drill (No. 24) to ensure a smooth swivel movement.

34) Place the bogie pivot mounting into its locating holes in the top of the bogie stretcher plate and using only sufficient glue to attach the plates, fit keeper plates over pivot spindles. Ensure pivot remains free to move until the liquid solvent has evaporated.

Some people prefer to use a larger piece of sheet styrene (not supplied) rather than the moulded keeper plates supplied.

35) If desired, fit the brake shoes on the inside of the sideframe. They should be positioned just off the wheels with the circle detail on the shoe just visible below the bottom of the side frame.

36) Fit the bolster detail centrally to the inside of the sideframe by placing the square beam against the back of the sideframe and butt against the underside of the bogie stretcher.

While the basic bogie assembly sets, identify and remove the bogie front channel, guard irons , speedo drive mount and bogie steps from the etched sheet (parts E3,E3a, E7, E14 and E2 respectively)

37) Fold up the bogie front channels (part 3) and locate the guard irons in the channel. The top of the guard iron (part E7) should be firmly against the top of the channel section, passing through the lowers slots - solder in place. See Bogie end channel 1.jpeg for clear view of channel detail.



38) Fold up the bogie step tread supports and mounting brackets (E2). See Bogie step and speedo drive.jpeg

39) Glue the bogie front channel to the front of the bogie with the bottom of the channel level with the bottom of the sideframe (superglue is recommended for this). See Bogie end channel in place.jpeg

40) Glue the speedo drive mounting (E14) to the front left axlebox with the spike facing right and down when fitted in place.

41) Glue the bogie steps in place. The front mounting is in line with the front spring hanger and the bottom step tread should be (approximately) level with the large spring mounting bobbin. Ensure the step is kept parallel to the side frame and attach the rear mounting to the top of the side frame. See Bogie step and speedo drive.jpeg.

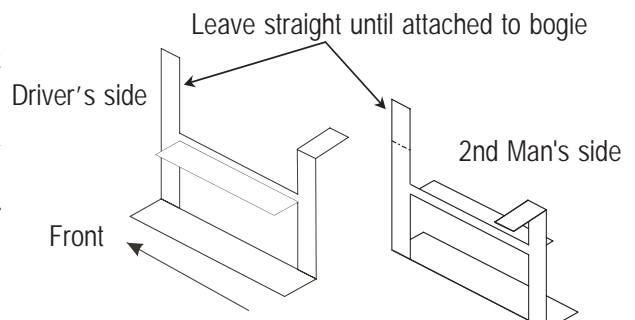

****TIP** Flattening the front spring hanger 'bobbin'

back to the level of the leaf spring greatly simplifies the fitting of the step mountings. Although un-prototypical, once painted the flatness is hardly noticeable.

POWER BOGIE

All the photographs referenced in this section will be found in the 'Power Bogie' folder on the CDROM, however you will find more images of bogies showing details in the various DMU construction folders. Also, the etched part numbers refer to the power-bogie etch NOT the main etches and are referenced from the Bogie Fret image shown on page 18 as well as on the disk. Also see the notes on gear noise on page 12.

IMPORTANT: Before removing the main stretcher plate from the fret please use the images 'Bogie Fret

TOP.jpg & **'Bogie Fret BOTTOM.jpg'** to identify the top and bottom faces. This is very important because the outline of the stretcher plate is symmetrical, but there is a top and bottom. The bottom is most easily identified by the balance beam pivot groove, shown circled in red on the image. Mark the underside of the plate so that you know which way up you've got the stretcher plate when assembling.

42.1) Remove the Main Stretcher Plate (E1) and Strengthening Channel (E2) from the fret and remove all burrs.

42.2) Fold up the Strengthening Channel into a channel shape and fold down the end piece to meet the edges of the channel.

42.3) Lay the Main Stretcher Plate on a flat surface with the underside uppermost and position the Strengthening Channel on the centerline using the holes as guides. Tip: insert the bogie pivot bush into the centre hole first and then align the position of the channel using the second hole. Ensure the channel is straight and square to the edges of the Main Stretcher Plate. Tack solder in place.

42.4) Once happy with the position of the Strengthening Plate, solder in place securely. Clean up any excess solder.

42.5) Solder a length of 0.9mm wire into the balance beam pivot groove ensuring it is flat to the face of the Stretcher Plate. Clean away any excess solder.

42.6) Fold down the balance beam securing tabs at each end of the balance beam pivot (see Bogie 1.jpg) and test fit the Balance Beam (E9), which is held in place by sliding a length of wire through the holes in the tabs. Carefully reduce the height of the pivot if required until the balance beam securing wire can be slid in place without difficulty without bending. The balance beam should rock easily with the wire in place, but it shouldn't be able to lift off the pivot. If you take too much material off the pivot, remove it and try again. Remove the balance beam.

42.7) At the front of the stretcher plate the end is folded down at 90° and then lowered using the other half etched grooves (on the top and bottom of the part) to form a joggle. The exact shape will be determined by the front channel later.

See Photo: Bogie 1.jpg & Bogie 2.jpg to see how the stretcher plate should look at this stage.

42.8) Remove the Sideframe Mountings (E3 & E4) from the etch, clean the edges and fold 90° along the half etched grooves.

42.9) Take the two sideframe mouldings and clean off any flash. Attach a sideframe to each of the mountings using the moulded pins as locators and noting that the folded sides of the mountings hang downward. Secure with superglue. See Photo: Bogie 3.jpg.

The bogie uses miniature ball races rather than pinpoint bearings you must be very careful completing the next step as not enough care could result in permanent damage to the ball races. Unfortunately we cannot offer our usual no quibble replacement guarantee for the ball races in the event of damage during fitting, but replacements can be purchased from our Camelford address.

42.10) The ball race is simply dropped into the rebate in the rear of the plastic sideframe, however it needs retaining. To retain the ball race run a very small amount of superglue around the edge of the outer race; try using a knife blade to apply the superglue. If you would rather keep away from the actual bearing whilst applying the glue, cut a small groove away from the hole at each side of the bearing insert the bearing and let the glue run to the edge of the bearing down the groove. See Photo: PBogie Ball Race.jpg. This photo shows where to make the small gluing grooves as a pair of red lines.

42.11) Clean up as required two centre bolster mouldings and attach to the rear of the sideframe mouldings. The bottom of the square section should be level with the underside of the sideframe moulding and the horizontal position should be central between the axle boxes. See Photo: Bogie speedo drive.jpg

42.12) Use the supplied nuts and bolts to (loosely) affix the sideframe mountings to the underside of the main stretcher plate. The mountings butt up to each side of the strengthening channel. Insert the drive

axle in place and tighten the bolts. If required use the supplied small fibre washers to reduce axle end float.

42.13) Remove the Rear End Channel With Location Lugs (E6) from the etch, clean the edges and fold into a channel along the half etched grooves. Attach to the end of the strengthening channel by first locating the lugs into the grooves in the back of the bogie sideframe moulding. See Photo: Bogie 4.jpg & Bogie 5.jpg.

42.14) Remove the Front End Channel With Guard Iron Slots (E5) and two Guard Irons (E10) from the etch, clean the edges and fold into a channel along the half etched grooves and affix the guard irons into the slots ensuring they are kept tight into the etched grooves.

42.15) Attach the front channel to the previously folded joggled mounting (Step 42.7). The exact position of the folds can now be adjusted so that the channel is level with the outer edges of the moulded sideframes.

42.16) Insert the Balance Beam Assembly making sure the chain sprocket is on the same side as the drive axle and secure in place with a wire retainer. See Photo: Bogie 6.jpg.

42.17) Fabricate pickups from the supplied wire and copper-clad components. Fitting the pickups is a bit tricky with this new arrangement as there's a lot of stuff to get around, but it can be done!

42.18) Fit the motor in place and attach the drive worm. Ensure the worm and worm-wheel are cantered together. Fit the drive chain ensuring it is not too tight as that will cause poor running, noise and excessive wear and chain stretch.

42.19) Glue the speedo drive mounting (E11) to the front left axle box with the spike facing right and down when fitted in place. Attach the large square casting from the speedo castings details over the etched part.

See Photo: Bogie speedo drive.jpg.

42.20) Fold up the bogie step tread supports and mounting brackets (E5).

42.21) Glue the bogie step mountings in place. The front mounting is in line with the front spring hanger and the bottom step tread should be (approximately) level with the large spring mounting bobbin. The step mounting legs have a half etch fold line on the back about 2mm from the top. Fold only one of these 90° and make a right and left hand pair - reinforce the fold. The straight leg is bent over to the front bogie channel once the step mounting is in place - reinforce with epoxy resin. Keep the steps parallel to the side frame and attach the rear mounting to the top of the side frame. See Photo: Bogie step and speedo drive.jpg, but note the front mounting leg has yet to be bent down to meet the bogie frame in the photograph.

42.22) The guard's door have additional steps fitted to the rear of the bogie, align the steps with the guard's door. Fold the step mounting as shown in the diagram above, but fold over the top of both mounting legs. See Photo: Bogie Showing Guard Steps.jpg.

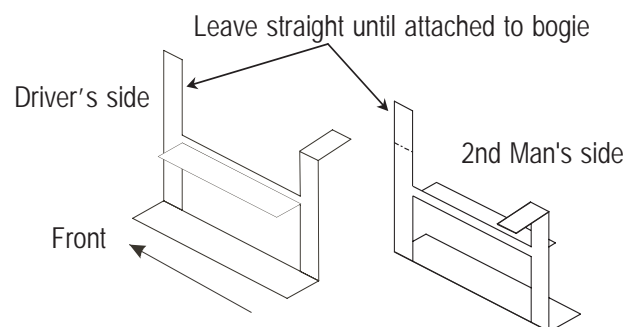

42.23) There are two different types of axle box covers supplied in the kit, use the slightly domed Timken covers.

42.24) Cut step treads 15mm long from the supplied 5mm wide styrene strip. Sand the edges of the treads to a slightly rounded shape and fix to the step supports as required.

42.25) The air horn (C5) should fit behind the bufferbeam on the driver's side, however, it's getting a bit crowded in there and it can also foul the bogie on tighter radius curves. We suggest fitting the horn to



the bogie front against the guard iron. If you opt to do this, reduce the length of the mounting bar to just above the first horn and butt it up to the bottom of the front channel.

BODY ASSEMBLY CONTINUED...

OK, the sides and ends will now be firmly fixed so will withstand the handling necessary to fit the roof.

43) Fit the three alloy roof retaining 'nuts' in the roof groove and slide to a position directly above that of the 4mm hole in the floor at each end - the outer edge of the turning should be approximately 7mm from the edge of the roof end. A third captive nut is included as an alternative method of preventing the floor from sagging in the middle once all the underframe castings are in place, see step 58 before proceeding and decide which method you wish to adopt.

44) Test fit the roof between the ends. Assuming everything has been assembled accurately the roof should be a snug fit. If tight, file and sand the end of the roof moulding until a snug fit is achieved. When the roof is in place the top of the sides will locate in the groove under the rain-strip. Fix the roof in place by initially applying solvent from the inside along the joint of the cabs/roof moulding then along the joint between the roof and the side mouldings, again from the inside.

LEAVE BODY TO HARDEN

45) Once the roof has firmly set, take time now to inspect the fit of the roof against the end moulding. Due to the different means by which the roof and ends are produced, it will be found that the alignment of the roof line and the ends require some blending. Car body filler ideal for this.

Once again, do take your time with step 46 not least because the roof and end joints will always be very visible.

If the roof vents and exhaust pipes were not fitted at Step 12 now is the time to do so. The roof vents will also offer the body some extra stability when it is placed upside-down for the following steps

UNDERFLOOR ASSEMBLY

NOTE: The molded ribs on the floor molding determine the underside of the floor molding!

46) Moving to the floor first check it will fit within the sides and end mouldings. It is likely that you will have to adjust the floor width to gain the best fit. Do this carefully removing the minimum amount evenly from each side to keep the floor central to the body. This is best done using a scraping action with a sharp blade. Any adjustment of the length can be affected by the use of a file.

47) Locate the two sprues containing the roof vents and bufferbeam on which you will find two other 'odd-shaped' end fillet pieces. Remove these pieces, clean as necessary and fix to the edge of the outer solebars at each end of the floor moulding as shown right.



***TIP - it may be prudent to back the end fillet with scrap styrene to improve its robustness as shown dotted in the diagram.*

48) Remove the bufferbeams from their sprues, clean flash, etc. and check the fit of the buffer shanks into the holes. Running a 3mm drill bit through the holes will clean out any flash. Also open up the coupling mounting hole and drill the mounting holes for the vac pipes as shown right.

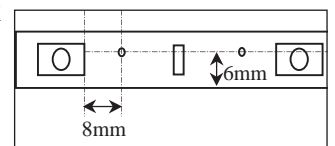

49) Fold the etched lamp irons (E12) to form a 'joggle' shape (right). The etched lamp iron mountings are fitted on the four 'lugs' moulded around the buffer shank holes, the buffer stocks are then glued onto the brass backing. Take care with this operation to ensure the various items remain square.

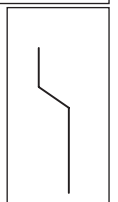

***TIP: Use the dill bit shank as a aid to align the three parts of the buffer assembly taking care not to glue the drill bit into the buffer hole! See 3 images Buffer Assembly (1, 2, 3).jpeg.*

50) Install the floor moulding into the body and temporarily secure into position with the supplied bolts. Now fit the bufferbeam to the underside of the cab ends, aligned centrally across the cab and butted against the end fillets to ensure vertical squareness. **DO NOT GLUE THE BUFFERBEAM TO THE END FILLETS BECAUSE IF YOU DO, YOU WILL NOT BE ABLE TO REMOVE THE FLOOR AGAIN!**

51) Starting with the cab ends add vac pipes and air horns (castings 5) to the drivers side just inside the floor front fillet piece.

The floor moulding can now be removed from the body and the remaining details fitted to the body and underframe.

ADDING THE REMAINING DETAILS

52) Locate the MU socket castings (casting 3) clean as required and fit to the two moulded mounting pads on the cab front.

53) Now would be a good time to assemble the control desk details as per the diagram and check for fit inside the cab.

54) Back on the outside of the cab you will need to drill 3x 0.7mm dia. holes through the seam between the cab end and the body side moulding. These holes apply only to the driver's door to the left end of the body on both sides because the holes can't be drilled, nor hinges fitted until the ends and sides are assembled. The hinges should be positioned to align with the other hinges (approx. 4.5mm, 20mm and 28.5mm as measured from the bottom of the body). Fit the hinges in the same manner as before. The short handrails (blue livery only), if required can now be fitted, but the grab handles could be left until after painting if you prefer them in the brass state on the finished model.

***Note - Door hinges are always on the left of a door as you look at the it.*

55) It has been found that the etched cab partitions are unfortunately too tall (this should only affect the initial batches of kits), remove them from the sheet and reduce in height by breaking off the rounded top just above the door opening (there's a handy half-etched line here). The reduced height of the partition is not noticeable from normal viewing positions. Check the width of the partition inside your body and trim as necessary to achieve a sensible fit through the previously cuts slots in the inner rib (step 2) remembering it will need to be able to removed with some ease.

***Note: the cab partition bottom fold needs to be folded away from the etched line contrary to normal practice in order to clear the body mounting bolt, i.e. the fold bends towards the cab front rather than away. Again this should affect only the initial batches of kits so check before making the bend.*

56) From scrap styrene cut two cab floors 14mm x 57mm (approx), fold the base of the drivers etched partition to 90 degrees (see note above) and fit to the floor. Fit into position trimming as necessary to achieve a snug fit. Add scrap styrene to the inner body sides to offer some additional support towards to upper part of the partition (do not obstruct the window openings and remember the glazing will need to be fitted later). Clean and fit the cab seat to this short cab floor positioned to roughly align with the curved recess in the cab desk and its back just clear of the partition. See mid body strengthener and cab walls.jpeg.

57) During the detailing of the underfloor of a demo model it was found that the floor sagged under the weight of the castings. To counter this a piece body stretchers are provided to fit centrally inside the body above the floor mounting lip. Once the underfloor had been detailed it was fitted into the body and drilled (through both the floor and the new support) and a self tapping screw fitted. See mid body strengthener and cab walls.jpeg for this additional support.

That just about covers the body detailing at this stage. Glazing and the etched security bars are left until the unit is painted.

UNDERFRAME DETAILS

***TIP - the underframe details are best tackled by studying the drawings and photographs.*

However it has been found helpful to construct small sub-assemblies and then attach these to the underfloor. The position of the guard's door is the key to parts positioning and, with the exception of the diesel engine sub-assemblies, all castings fit at the edge of the floor against the sole bars. The diesel engines mount in the centre of the floor. So here goes...

58.0) Clean the flash from all the components.

58.1) Fit the radiator grills (E8) onto the front of the radiator castings (casting 23).

58.2) Fit castings 8, 13 and 17 to the diesel engine (casting 27) see right.

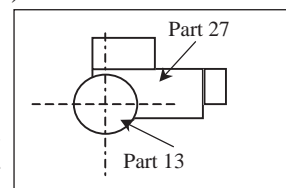

58.3) Solder the two battery boxes to the fuel tanks. The back of the battery box should be in line with the back of the fuel tank casting and aligned one to the left and one to the right edges of their respective tanks (see drawings 3 and 4 for positions).

58.4) Scribe a line on the underside of the two remaining fuel tanks 10mm from the back edge to aid the alignment the electrical boxes that will be fitted to them next.

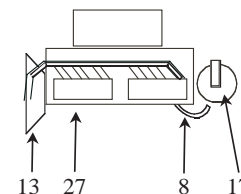

58.5) Fix castings 14 and 18 to the etched bracket E9. The sub-assembly is fixed to the fuel tank aligned to the scribed line (use drawing 3 for left-right alignment).

58.6) Solder the various electrical boxes (castings 11, 16 & 4) to the other fuel tank against the scribed line using drawing 4 for reference. The conduit between part 11 and 4 can be fashioned from 0.8mm brass, or soft copper wire.

58.7) Glue a tank patch and tank gauge (E10 and E11) to the sloping face of each tank about 3mm in from each end (the appearance is symmetrical with the gauges positioned to be nearest the bogie).

58.8) Probably the trickiest on the underframe detailing is creating the exhaust pipes. Annealed 1.5mm copper wire was used on the demo models. The exhausts both travel towards the guard's compartment and then pass up through the floor. Since the exact position of the point of entry into the floor isn't known, aim for a point just behind of the power bogie (about 18mm from the rear of the cut out in the underframe for the motor). Once the pipes have been formed solder to the exhaust pipe stub cast onto the diesel engine just prior to fitting the engine to the floor. See cravens underframe002.jpeg.

59) Having produced the basic sub-assemblies, score the underside of the floor moulding as appropriate and fix them in position.

60) Locate the remaining speedo drive parts (E13 and small 'square' castings from casting 6) and prior to fitting file the spike of the etched parts quite thin to enable thin wire sheathing to be pushed over later. Fit the speedo drive backing etched part to the sole bar 37mm from end of floor moulding with spike pointing down with the casting glue in place on top.

61) Cut 6 off 30mm x 5mm, 4 off 20mm x 5mm and 8 off 15mm 5mm pieces of 0.7mm (30 thou) styrene as step treads.

****TIP** - In each case the outer edges should not be left too square cut, i.e. round off the upper edges and slightly round the corners. The steps were wooden and soon became worn.

62) Fix the step treads to the solebars, the 20mm steps for the passenger and cab doors and the 30mm steps for the baggage/guard's door. The steps should be aligned with the previously made marks and level with the bottom of the solebar. Additional strength can be gained by adding a strip of styrene to the front of the solebar in line with the step, once painted it is hardly noticeable. The 15mm treads are fitted to the bogies step supports.

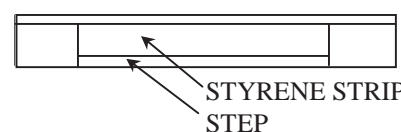

That just about covers the basics of the underframe details. Of course there is a great deal more under there, but you've got a good starting point for a more detailed model, or sufficient for most situations. If you really 'go to town' with the underframe detailing please do share your work

with us and we will display your handiwork on our web site and include your pictures on future information disks (only with your permission of course in both cases).

FINISHING

63) With the main construction now completed it is time to prepare the model for painting. Whilst this consists of mainly cleaning and washing of all the parts, it also gives you another opportunity to check the security of the various fittings. Anything that cannot stand cleaning now will probably not withstand long-term use, so it's better to have bits falling off now than later! Re-affix as required.

Painting is not a subject to be condensed into a few lines, so we will assume that you already have the means to produce the required livery (if not we can help). Liveries carried were green with speed whiskers and dark grey roof (as built); green with light grey roof and small yellow front warning panel and finally corporate blue with full yellow ends. One unit entered departmental service and was named Hydra (kit available). Dates for the livery changes are vague but seem to be in line with other livery changes. We recommend the excellent transfers supplied by Fox.

The only item we must mention is that concerning the side windows. There are eight windows with a single cross bar to depict a non-opening top light. This bar will need painting in the main body colour prior to fitting the windows. Also, don't forget to paint the etched security bars which can be painted whilst still on the remaining frets. We assume you will paint the detail colours at this stage (bufferbeams, control desks and underframe details, etc.)

***TIP - To improve colour intensity of the glazing bars (bearing in mind the plastic is clear) apply a thin coat of grey primer, followed by a thin coat of black and finally thin coats of body colour.*

FINAL ASSEMBLY

64) Starting inside the body, find the windscreens you put in a safe place some time ago and fit using small amounts of solvent. Alternatively, if you have some RC Modellers glue to hand, dilute a small amount with water and apply from the inside with a small brush to the edge of the glazing allowing capillary action to draw the liquid into the joint.

65) Fit all internal windows in a similar manner, i.e. not too much solvent in any single application.

66) Fit the control desks on to the desk supports with two part epoxy and whilst they are curing cut the etched security bars (E5 & E6) from the frets. Just slightly bend the top and bottom mountings so that the bars stand clear of the glazing - don't over do it!

***TIP - RC MODELLERS glue is ideal for fixing the security bars and windows (when slightly diluted) in place.*

67) Check the fit of the buffers in the stocks once again for a sliding fit, adjust as necessary. Fit the buffers into the stocks (don't forget the springs!) and secure in position by supergluing the retaining ring over the buffer shank protruding through the back of the bufferbeam. The ring should be level with the rear of the buffer shank. Do not be too extravagant with the superglue as it is easy to end up with solid buffers... Also fit the couplings.

68) Fit the cab partitions in place (you may wish to install a driver in one end at this stage), carefully insert the floor assembly and secure into position with the long bolts provided. Don't forget the centre floor support or your DMU will end up with a sway-backed underframe!

69) Mount the bogies and ensure they are free to rotate. The speedo drives cables are made from short lengths of silicon tube. Do not make the link too short as it will restrict bogie movement, however too long and it may snag on track side components. Start with about 35mm and work back from there until it looks right, but still gives sufficient bogie movement.

70) Bend the wiper 'blades' 90 degrees to the arms so that they present a blade edge to the windscreen ensuring you create two left and two right handed wipers. Solder a piece of 0.4mm wire through the mounting holes in the arms, paint black and fix into the holes previously drilled above the upper edges of the windscreen beading. The wipers are intended to be in the parked positions, which is up against

the outer edges of the windscreens. See craven end 4.jpg.

71) Fit all door, commode and grab handles. It should also be noted the guard's door has a special etched door handle (E17).

Et Voila - the task is complete!

We hope you have enjoyed building this kit and welcome your comments.

SHAWN KAY FEBRUARY 2017

GEAR NOISE

We have had some modellers complain of excessive gear noise, which is hard to explain as the gears are very good quality and so should perform very well. So here are a few tips on how to get the best out of the components:

- 1) Once the motor bogie has been assembled, check the mesh of the worm and gear wheel. The worm should sit in the centre of the gear wheel (horizontally) and that there should be very little backlash. If you can rotate the gear back and forth so that the teeth rattle against the worm, elongate the motor mounting holes (including the central hole) slightly towards the drive gear and test again. You don't want the worm and gear to be hard against each other, but a snug fit with minimal backlash.
- 2) Mount the worm in a rotary tool (or cordless drill with speed control) and turn it slowly in both directions applying a metal polish (such as Brasso) with a cloth. You must get the polish right into the groove of the worm and apply pressure to both surfaces of the groove. Do this several times back and forth, but you probably won't be able to tell you've done it enough just by looking, so give it one more go! Polish off the abrasive.
- 3) Re-mount the worm and now make sure the worm is in the centre of the gearwheel VERTICALLY, i.e. the gear meshes with the centre of the worm in length. If the worm sits too high, or too low, the start of the worm groove can clip the gear teeth in one direction, or the other adding more noise. Turning the motor by hand and watching how the worm and gear interact is the only way to be sure you've got it right.
- 4) Run the motor at a low speed and apply a small amount of abrasive paste (toothpaste is a favourite, or even brasso again - sparingly) and apply light pressure to the drive wheels so that the gears have some work to do. Repeat in both directions for some time. If you use brasso, or something similar, adding drops of light oil onto the gears will keep the polishing action going longer.
- 5) Clean off all traces of the polishing compound and apply a light grease to the gears.

Take your time and you will be rewarded with a quiet and reliable power unit.

DRAWING 1

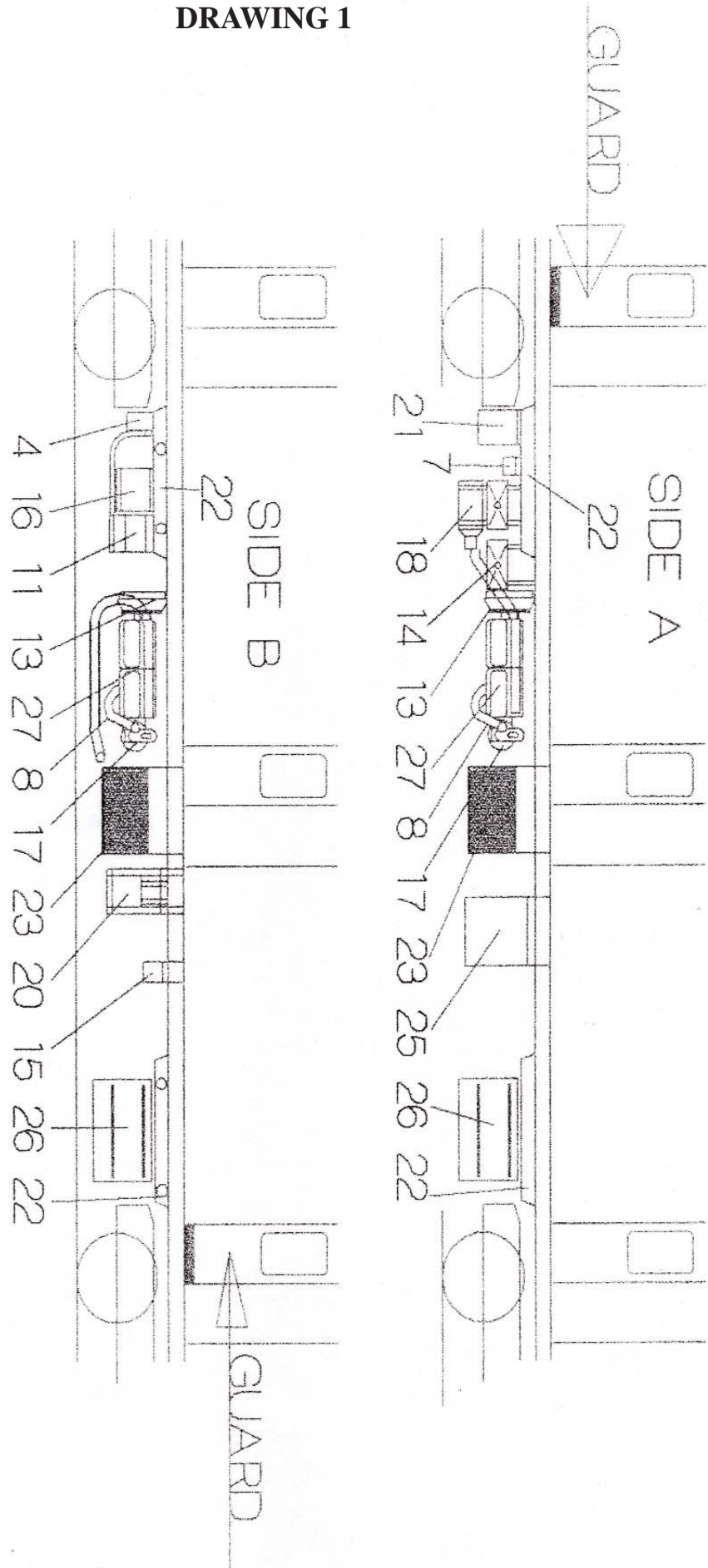

EASY BUILD CRAVENS CLASS 129 UNDERFRAME PARTS POSITION
(SCALE DRAWING FOR ACCURATE POSITION OF CASTINGS)

DRAWING2

All measurements (in mm) taken from Guard's end

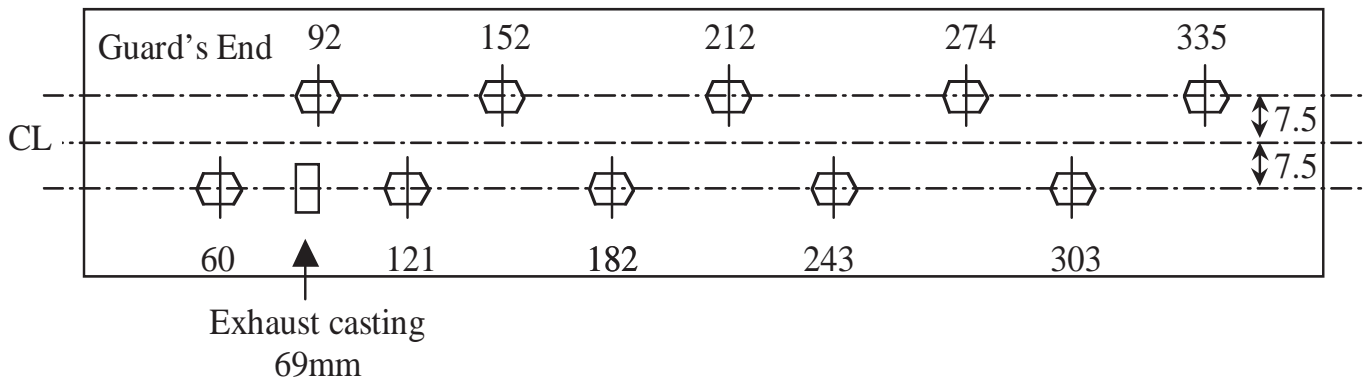

CASTINGS

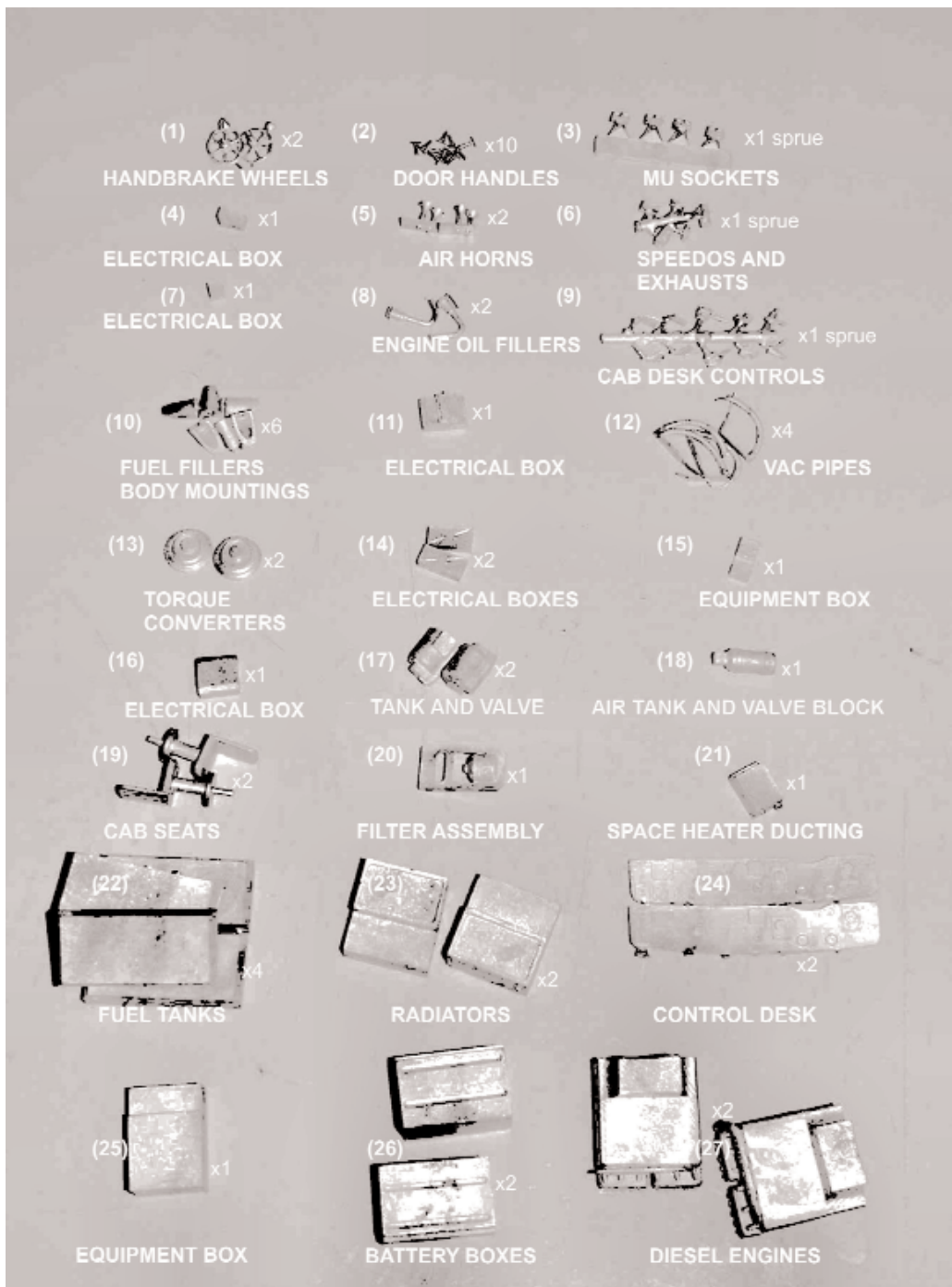

DRAWING 3 - UNDERFRAME VIEWED WITH GUARD'S COMPARTMENT TO LEFT

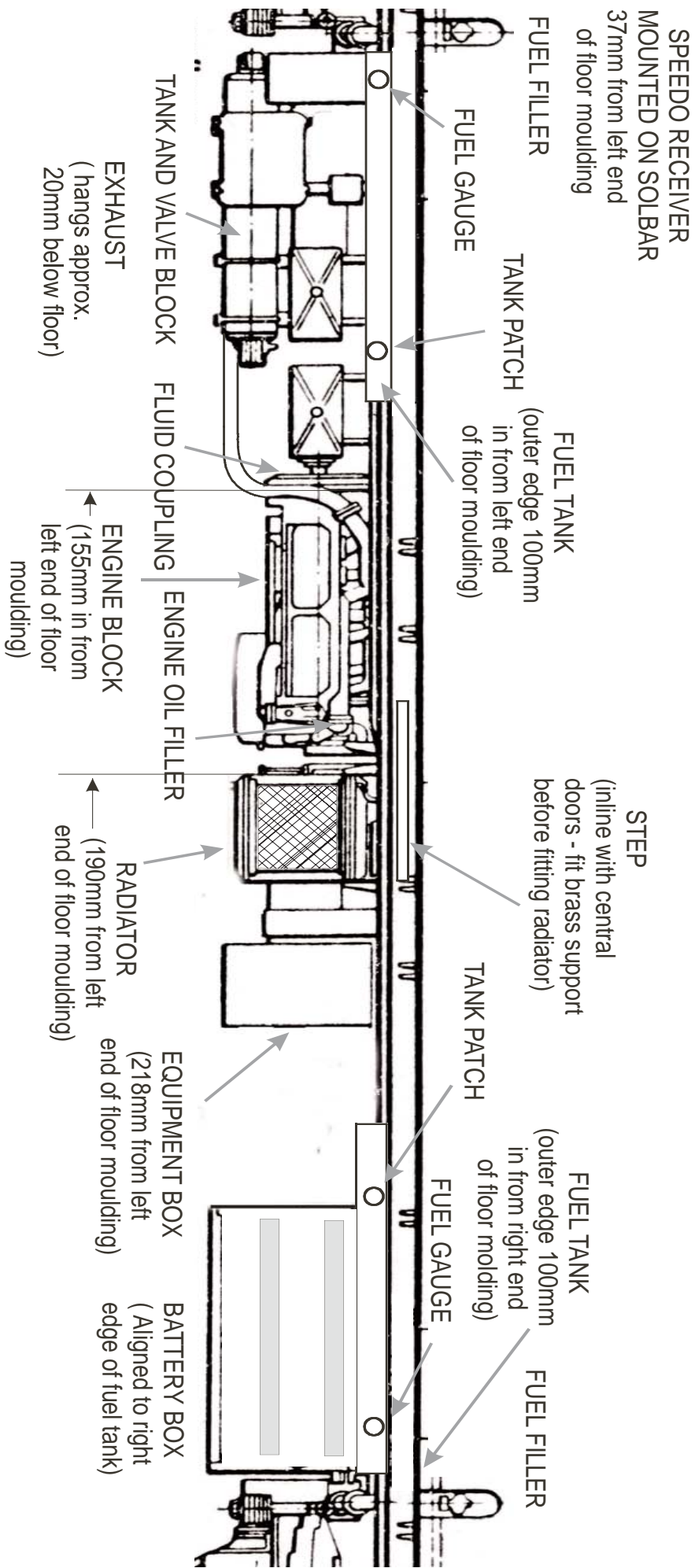

DRAWING 4 - UNDERFRAME VIEWED WITH GUARD'S COMPARTMENT TO RIGHT

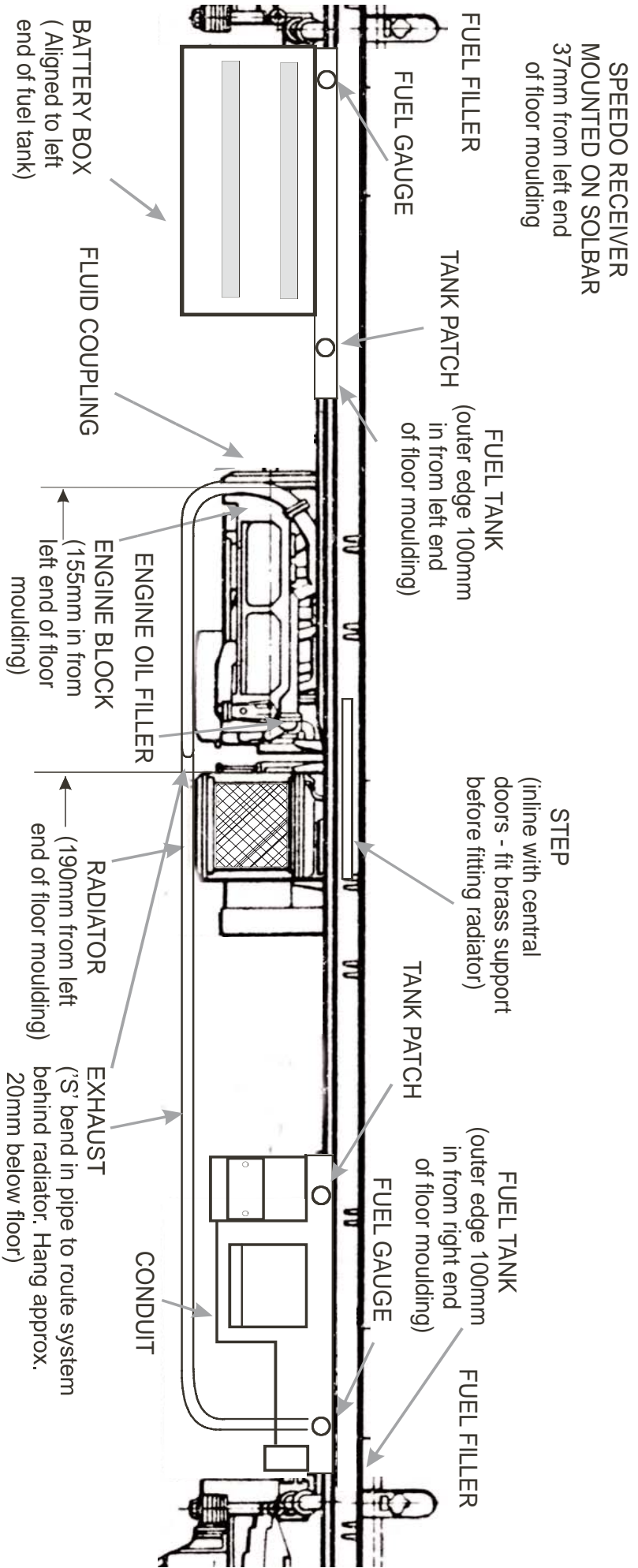

ETCHED PARTS SPECIFIC TO CRAVENS UNIT

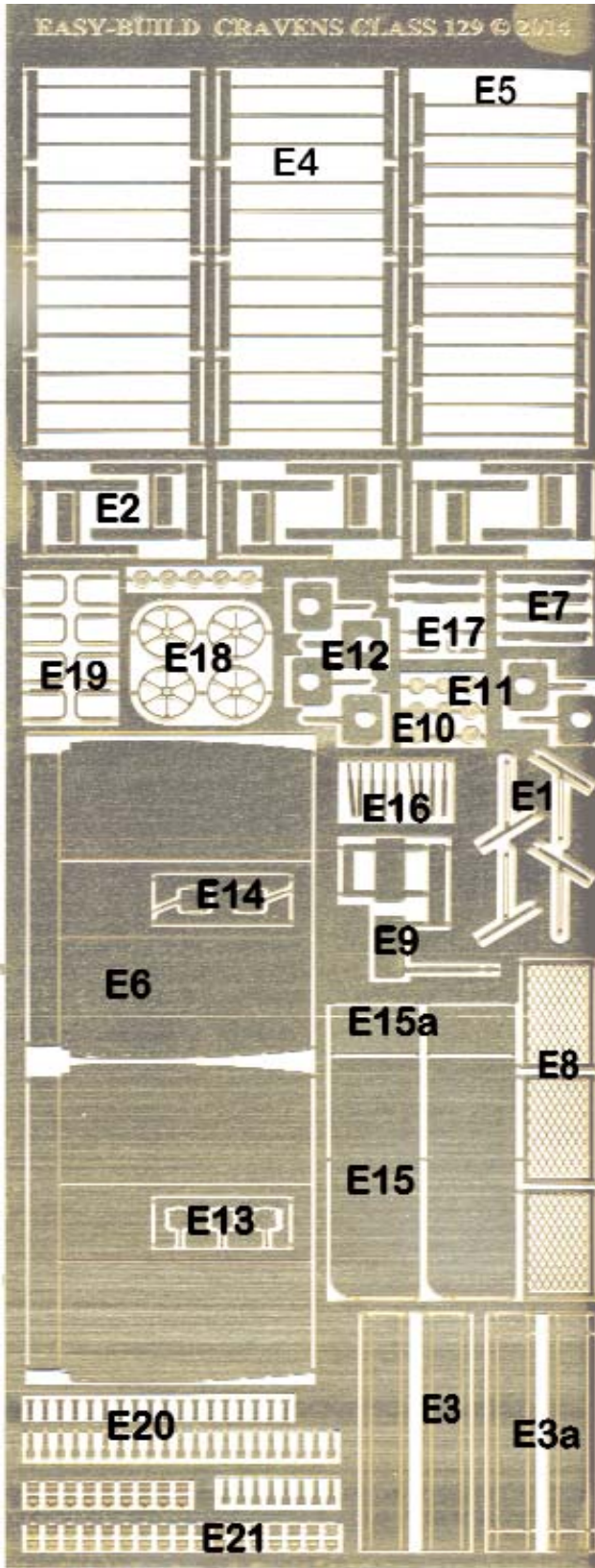

Key:

- E1) Windscreen Wipers
- E2) Bogie Step Supports
- E3) Bogie Channel
- E3a) Bogie Channel With Guard Iron Slots
- E4) Window Security Bars
- E5) Door Window Security Bars
- E6) Cab Partitions
- E7) Guard Irons
- E8) Radiator Grille
- E9) Castings Support (for C14 & C18)
- E10) Fuel Tank Patch
- E11) Fuel Tank Gauge
- E12) Lamp Irons
- E13) Speedo Receiver Backing (for Small C6)
- E14) Speedo Sender Backing (for Large C6)
- E15) Control Desk Base
- E15a) Control Desk Middle Support
- E16) Baggage Door Lever Handles
- E17) Guard's Door Handles
- E18) Handbrake Wheels
- E19) Commode handles
- E20) Hinge Pins
- E21) Hinge 'Butterflies' (long and short)

CONTROL DESK DETAILS

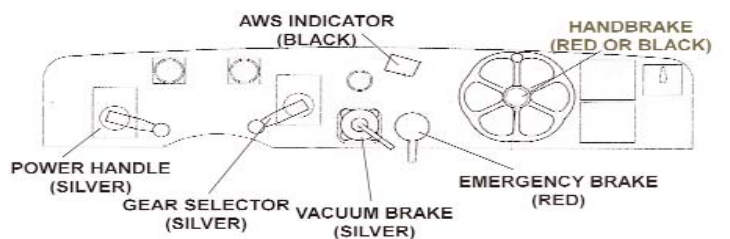

MODIFICATION TO FLOOR

Since the floor of the power car was designed we've had to obtain our gear sets from a different supplier. This change meant we had to alter the position of the motor, which in turn created a problem with the aluminium bogie mounting. If fitted as described the motor will foul the edge of the round bogie mounting. So, with the round aluminium mounting is securely in place as described in the main text, file, or cut off the edge of the floor motor opening and mounting sufficiently to allow the motor to move through its full range. See diagram below.

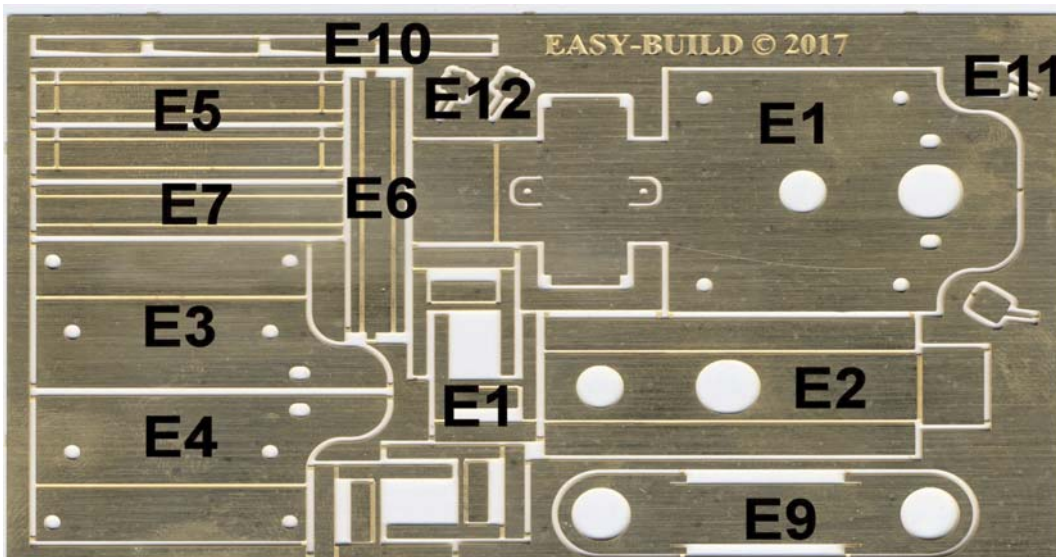
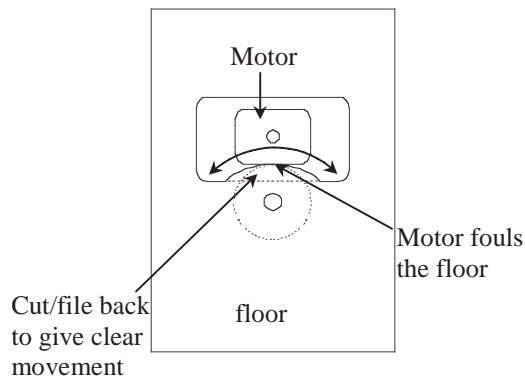

**POWER
BOGIE ETCH**